

EDILGRAPPA

INDEX INDICE



Since 1977 EDILGRAPPA SRL designs and manufactures in Italy a wide range of high quality tools for Rescue and industrial applications. To meet the demand of nowadays dynamic and fast changing world we adopt flexibility and innovation as standard in every project we bring to the international market. Both organization and manufacturing process is based on ISO 9001 quality standards to guarantee that Edilgrappa tool is safe and reliable. All our activities are carried on paying attention to the social role of the company, with high respect to the environment and norms, aware of the fact that every action always originates from the man. The ongoing research and continuous development which Edilgrappa is taking from many years, already permits, and so in the future, to achieve increasingly ambitious goals.

Dal 1977 EDILGRAPPA SRL produce in Italia e distribuisce nel mondo una vasta gamma di attrezzatura per il settore Industriale, Edile e del Soccorso caratterizzata da elevati standard qualitativi e forte spinta all'innovazione. Edilgrappa è focalizzata da molti anni in ricerca e sviluppo in risposta ai continui mutamenti del mercato, raggiungendo obiettivi sempre più ambiziosi, soddisfacendo richieste da ogni Paese. Sia il processo di organizzazione che quello di produzione si basano su standard di qualità ISO 9001 per garantire che l'attrezzatura Edilgrappa sia sicura e affidabile. Ognuna delle nostre attività presta attenzione al ruolo sociale dell'azienda, nel rispetto dell'ambiente e delle norme, consapevoli del fatto che ogni azione ha sempre origine dall'uomo.

CE

p. 06	01	REBAR CUTTERS TAGLIA TONDINI BENDERS PIEGATRICI STRAIGHTENERS RADDRIZZATRICI
p. 22	02	MULTI-TOOLS ATTREZZI MULTIFUNZIONE
p. 28	03	CHAIN CUTTERS TAGLIA CATENE CABLE/ROPE CUTTERS TAGLIA CAVI/FUNI
p. 34	04	PUNCHERS PUNZONATRICI NIBBLERS RODITRICI FLAT BAR CUTTERS TAGLIA BARRE PIATTE
p. 46	05	CONTROLLED DEMOLITION DEMOLIZIONE CONTROLLATA RECYCLING RECUPERO DECOMMISSIONING SMANTELLAMENTO
p. 58	06	HYDRAULIC POWER UNITS CENTRALINE IDRAULICHE
p. 62	07	ACCESSORIES ACCESSORI

LEGEND LEGENDA

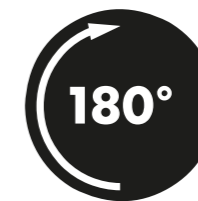

180° ROTATING HEAD
TESTA ORIENTABILE 180°

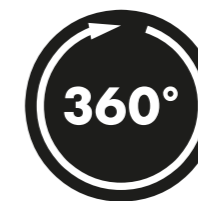

360° ROTATING HEAD
TESTA ORIENTABILE 360°



BATTERY-POWERED EQUIPMENT
ATTREZZATURA A BATTERIA



LED LIGHT
LUCE LED



SINGLE ACTING
SEMPLICE EFFETTO

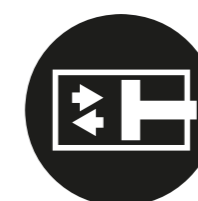

DOUBLE ACTING
DOPPIO EFFETTO



EXCAVATOR ATTACHMENT
ACCESSORIO PER ESCAVATORE

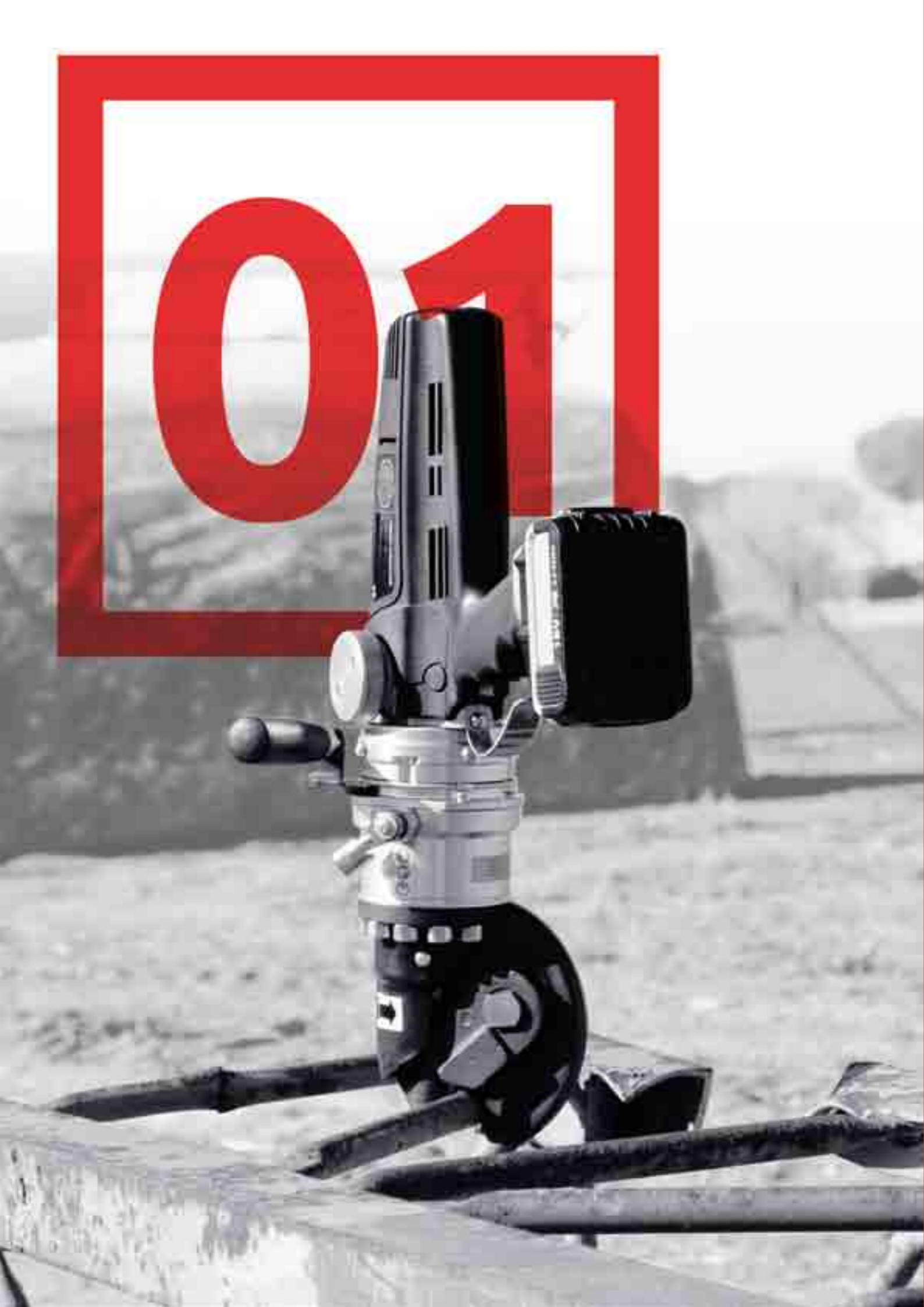

REBAR CUTTERS TAGLIA TONDINI
BENDERS PIEGATRICI
STRAIGHTENERS RADDRIZZATRICI

PRO-CUT 12 - 18V

Battery-powered cutter - Cesoa a batteria
150.03478



Cutting capacity	Capacità di taglio	Ø 12 mm (Rm: 70 daN/mm ²)
Cutting force	Forza di taglio	120 kN (12.2 t)
Working pressure	Pressione d'esercizio	30 MPa (300 bar)
Power supply	Alimentazione	Battery - Batteria
Motor	Motore	18V
Head rotation	Rotazione testa	360°
Cylinder	Cilindro	Single acting Semplice effetto
Weight*	Peso*	6.5 kg
Dimensions LxWxH*	Dimensioni LxPxH*	494 x 184 x 303 mm

*Dimensions and weight w/o battery / Dimensioni e peso senza batteria

- Rebars, steel and welded meshes, padlocks, seals, chains
Tondini, reti metalliche ed elettrosaldate, lucchetti, sigilli, catene
- Long battery life
Batteria a lunga durata
- Ideal for building and industrial works
Ideale per edilizia e industria
- 360° rotating head
Testa rotante 360°
- Small dimensions allow to reach confined places
Le dimensioni ridotte permettono di raggiungere posti stretti

Battery and charger not included
Batteria e caricabatteria non inclusa

MU16 - 18V

Battery-powered cutter - Cesoa a batteria
150.03007



Cutting capacity	Capacità di taglio	Ø 16 mm (Rm: 70 daN/mm ²)
Cutting force	Forza di taglio	171 kN (17.4 t)
Working pressure	Pressione d'esercizio	56 MPa (560 bar)
Power supply	Alimentazione	Battery - Batteria
Motor	Motore	18V
Head rotation	Rotazione testa	360°
Cylinder	Cilindro	Single acting Semplice effetto
Weight*	Peso*	8.6 kg
Dimensions LxWxH*	Dimensioni LxPxH*	486 x 184 x 303 mm

*Dimensions and weight w/o battery / Dimensioni e peso senza batteria

- Rebars, steel and welded meshes, padlocks, seals, chains
Tondini, reti metalliche ed elettrosaldate, lucchetti, sigilli, catene
- Long battery life
Batteria a lunga durata
- Ideal for building, industrial and rescue works
Ideale per edilizia, industria e soccorso
- 360° rotating head
Testa rotante 360°
- Small dimensions allow to reach confined places
Le dimensioni ridotte permettono di raggiungere posti stretti

Battery and charger not included
Batteria e caricabatteria non inclusa

SILVERCUT 16 - 18V

Battery-powered cutter - Cesoa a batteria
150.02541



Cutting capacity	Capacità di taglio	Ø 16 mm (Rm: 70 daN/mm ²)
Cutting force	Forza di taglio	127 kN (13 t)
Working pressure	Pressione d'esercizio	55 MPa (550 bar)
Power supply	Alimentazione	Battery - Batteria
Motor	Motore	18V
Head rotation	Rotazione testa	360°
Cylinder	Cilindro	Single acting Semplice effetto
Weight*	Peso*	8.6 kg
Dimensions LxWxH*	Dimensioni LxPxH*	479 x 174 x 303 mm

*Dimensions and weight w/o battery / Dimensioni e peso senza batteria

- Rebars, steel and welded meshes, padlocks, seals, chains
Tondini, reti metalliche ed elettrosaldate, lucchetti, sigilli, catene
- Long battery life
Batteria a lunga durata
- Ideal for building and industrial works
Ideale per edilizia e industria
- 360° rotating head
Testa rotante 360°
- Small dimensions allow to reach confined places
Le dimensioni ridotte permettono di raggiungere posti stretti

Battery and charger not included
Batteria e caricabatteria non inclusa

SILVERCUT 20 - 18V

Battery-powered cutter - Cesoa a batteria
150.03656



Cutting capacity	Capacità di taglio	Ø 20 mm (Rm: 70 daN/mm ²)
Cutting force	Forza di taglio	188 kN (19.2 t)
Working pressure	Pressione d'esercizio	55 MPa (550 bar)
Power supply	Alimentazione	Battery - Batteria
Motor	Motore	18V
Head rotation	Rotazione testa	360°
Cylinder	Cilindro	Single acting Semplice effetto
Weight*	Peso*	9.1 kg
Dimensions LxWxH*	Dimensioni LxPxH*	505 x 176 x 303 mm

*Dimensions and weight w/o battery / Dimensioni e peso senza batteria

- Rebars, steel and welded meshes, padlocks, seals, chains
Tondini, reti metalliche ed elettrosaldate, lucchetti, sigilli, catene
- Long battery life
Batteria a lunga durata
- Ideal for building and industrial works
Ideale per edilizia e industria
- 360° rotating head
Testa rotante 360°
- Small dimensions allow to reach confined places
Le dimensioni ridotte permettono di raggiungere posti stretti

Battery and charger not included
Batteria e caricabatteria non inclusa

PRO-CUT 12

Corded cutter - Cesoa a filo

230V 150.01298 - 120V (US plug) 150.01956

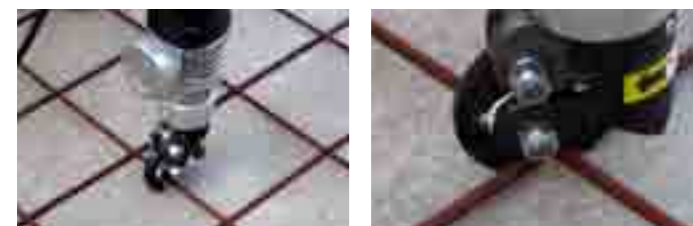

Cutting capacity	Capacità di taglio	Ø 12 mm (Rm: 70 daN/mm ²)
Cutting force	Forza di taglio	120 kN (12.2 t)
Working pressure	Pressione d'esercizio	30 MPa (300 bar)
Power supply	Alimentazione	Mains Rete elettrica
Motor	Motore	230V: 1200 W - 50 Hz - 5.8 A 120V: 1100 W - 60 Hz - 9.2 A
Cylinder	Cilindro	Single acting Semplice effetto
Weight	Peso	7.4 kg
Dimensions LxWxH	Dimensioni LxPxH	514 x 123 x 138 mm

Accessories Accessori

Rear extension handle	Impugnatura posteriore prolungata	150.01364
-----------------------	-----------------------------------	-----------

- Rebars, rods, threaded bars
Tondini, barre tonde, barre filettate
- Ideal for building and industrial works
Ideale per edilizia e industria
- Small dimensions allow to reach confined places
Le dimensioni ridotte permettono di raggiungere posti stretti

PRO-CUT 12 TOP HANDLE / IMPUGNATURA SUPERIORE

Corded cutter - Cesoa a filo

230V 150.01326 - 120V (US plug) 150.02450

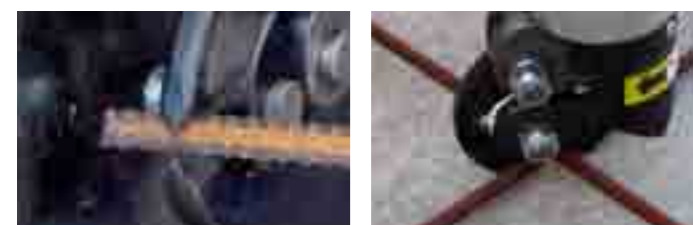

Cutting capacity	Capacità di taglio	Ø 12 mm (Rm: 70 daN/mm ²)
Cutting force	Forza di taglio	120 kN (12.2 t)
Working pressure	Pressione d'esercizio	30 MPa (300 bar)
Power supply	Alimentazione	230 - 120 Vac
Motor	Motore	230V: 1200 W - 50 Hz - 5.8 A 120V: 1100 W - 60 Hz - 9.2 A
Cylinder	Cilindro	Single acting Semplice effetto
Weight	Peso	7.4 kg
Dimensions LxWxH	Dimensioni LxPxH	411 x 123 x 211 mm

- Rebars, steel and welded meshes, padlocks, seals, chains
Tondini, reti metalliche ed elettrosaldate, lucchetti, sigilli, catene
- Ideal for building and industrial works
Ideale per edilizia e industria
- Small dimensions allow to reach confined places
Le dimensioni ridotte permettono di raggiungere posti stretti

MU16

Corded cutter - Cesoa a filo

230V 150.01838 - 120V (US plug) 150.01235 - 110V (UK plug) 150.01925

**Accessories Accessori**

Rear extension handle	Impugnatura posteriore prolungata	150.01364
Side handle	Impugnatura laterale	150.01914

- Rebars, steel and welded meshes, padlocks, seals, chains
Tondini, reti metalliche ed elettrosaldate, lucchetti, sigilli, catene
- Ideal for building and industrial works
Ideale per edilizia e industria
- Small dimensions allow to reach confined places
Le dimensioni ridotte permettono di raggiungere posti stretti

Cutting capacity	Capacità di taglio	Ø 16 mm (Rm: 70 daN/mm ²)
Cutting force	Forza di taglio	171 kN (17.4 t)
Piston Force	Forza al pistone	147 kN (15 t)
Working pressure	Pressione d'esercizio	56 MPa (560 bar)
Power supply	Alimentazione	Mains Rete elettrica
Motor	Motore	230V: 1100 W - 50 Hz - 5.3 A 120V: 1200 W - 60 Hz - 10 A
Cylinder	Cilindro	Single acting Semplice effetto
Weight	Peso	9.5 kg
Dimensions LxWxH	Dimensioni LxPxH	525 x 124 x 148 mm

MU16 STRAND CUTTER / TAGLIA TREFOLO

Corded strand cutter - Cesoa taglia trefolo a filo

230V 150.01285 - 120V 150.02803



Cutting capacity	Capacità di taglio	Ø 12 mm (Rm: 160 daN/mm ²)
Cutting force	Forza di taglio	208 kN (21.1 t)
Piston Force	Forza al pistone	178 kN (18.2 t)
Working pressure	Pressione d'esercizio	68 MPa (680 bar)
Power supply	Alimentazione	Mains Rete elettrica
Motor	Motore	230V: 1100 W - 50 Hz - 5.3 A 120V: 1200 W - 60 Hz - 10 A
Cylinder	Cilindro	Single acting Semplice effetto
Weight	Peso	9.5 kg
Dimensions LxWxH	Dimensioni LxPxH	525 x 124 x 148 mm

SILVERCUT 16

Corded cutter - Cesoa a filo

230V 150.01280 - 120V (US plug) 150.01904



Cutting capacity	Capacità di taglio	Ø 16 mm (Rm: 70 daN/mm ²)
Cutting force	Forza di taglio	127 kN (13 t)
Working pressure	Pressione d'esercizio	45 MPa (450 bar)
Power supply	Alimentazione	Mains Rete elettrica
Motor	Motore	230V: 1200 W - 50 Hz - 5.8 A 120V: 1100 W - 60 Hz - 9.2 A
Cylinder	Cilindro	Single acting Semplice effetto
Weight	Peso	7.5 kg
Dimensions LxWxH	Dimensioni LxPxH	397 x 113 x 212 mm

- Rebars, rods, threaded bars
Tondini, barre tonde, barre filettate
- Ideal for building and industrial works
Ideale per edilizia e industria
- Small dimensions allow to reach confined places
Le dimensioni ridotte permettono di raggiungere posti stretti

SILVERCUT 20

Corded cutter - Cesoa a filo

230V 150.01300 - 120V (US plug) 150.01898



Cutting capacity	Capacità di taglio	Ø 20 mm (Rm: 70 daN/mm ²)
Cutting force	Forza di taglio	188 kN (19.2 t)
Working pressure	Pressione d'esercizio	55 MPa (550 bar)
Power supply	Alimentazione	Mains Rete elettrica
Motor	Motore	230V: 1100 W - 50 Hz - 5.3 A 120V: 1200 W - 60 Hz - 10 A
Cylinder	Cilindro	Single acting Semplice effetto
Weight	Peso	10 kg
Dimensions LxWxH	Dimensioni LxPxH	437 x 113 x 225 mm

- Rebars, rods, threaded bars
Tondini, barre tonde, barre filettate
- Ideal for building and industrial works
Ideale per edilizia e industria
- Small dimensions allow to reach confined places
Le dimensioni ridotte permettono di raggiungere posti stretti

MU18

Corded cutter - Cesoa a filo

230V 150.00689 - 120V 150.02031



Cutting capacity	Capacità di taglio	Ø 18 mm (Rm: 70 daN/mm ²)
Cutting force	Forza di taglio	148 kN (15.1 t)
Working pressure	Pressione d'esercizio	56 MPa (560 bar)
Power supply	Alimentazione	Mains Rete elettrica
Motor	Motore	230V: 1100 W - 50 Hz - 5.3 A 120V: 1200 W - 60 Hz - 10 A
Cylinder	Cilindro	Single acting Semplice effetto
Weight	Peso	9 kg
Dimensions LxWxH	Dimensioni LxPxH	415 x 122 x 225 mm

- Rebars, rods, threaded bars
Tondini, barre tonde, barre filettate
- Ideal for industrial works
Ideale per industria
- Small dimensions allow to reach confined places
Le dimensioni ridotte permettono di raggiungere posti stretti

T22N

Corded cutter - Cesoa a filo

230V 150.01265 - 120V (US plug) 150.02089



Cutting capacity	Capacità di taglio	Ø 22 mm (Rm: 70 daN/mm ²)
Cutting force	Forza di taglio	223 kN (22.8 t)
Working pressure	Pressione d'esercizio	58 MPa (580 bar)
Power supply	Alimentazione	Mains Rete elettrica
Motor	Motore	230V: 1400 W - 50 Hz - 6.8 A 120V: 1100 W - 60 Hz - 9.2 A
Cylinder	Cilindro	Single acting Semplice effetto
Weight	Peso	13 kg
Dimensions LxWxH	Dimensioni LxPxH	411 x 123 x 211 mm

Accessories Accessori

Lifting hook	Gancio di sollevamento	150.02703
--------------	------------------------	------------------

- Rebars, rods, threaded bars
Tondini, barre tonde, barre filettate
- Ideal for building and industrial works
Ideale per edilizia e industria
- Small dimensions allow to reach confined places
Le dimensioni ridotte permettono di raggiungere posti stretti

T26N

Corded cutter - Cesoia a filo

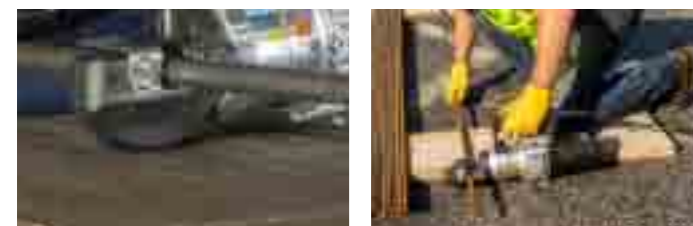
230V 150.01873 - **120V (US plug)** 150.02090

Cutting capacity	Capacità di taglio	Ø 26 mm (Rm: 70 daN/mm ²)
Cutting force	Forza di taglio	329 kN (33.6 t)
Working pressure	Pressione d'esercizio	58 MPa (580 bar)
Power supply	Alimentazione	230 - 120 Vac
Motor	Motore	230V: 1400 W - 50 Hz - 6.8 A 120V: 1100 W - 60 Hz - 9.2 A
Cylinder	Cilindro	Single acting Semplice effetto
Weight	Peso	15.7 kg
Dimensions LxWxH	Dimensioni LxPxH	468 x 140 x 258 mm

Accessories Accessori

Lifting hook	Gancio di sollevamento	110.06901
--------------	------------------------	------------------

- Rebars, rods, threaded bars
Tondini, barre tonde, barre filettate
- Ideal for building and industrial works
Ideale per edilizia e industria
- Small dimensions allow to reach confined places
Le dimensioni ridotte permettono di raggiungere posti stretti

**T16 ELECTRIC DRIVE / AZIONAMENTO ELETTRICO**

Cutter - Cesoia

150.00608



Cutting capacity	Capacità di taglio	Ø 16 mm (Rm: 70 daN/mm ²)
Cutting force	Forza di taglio	163.8 kN (16.7 t)
Working pressure	Pressione d'esercizio	70 MPa (700 bar)
Cylinder	Cilindro	Double acting Doppio effetto
Weight	Peso	5 kg
Dimensions LxWxH	Dimensioni LxPxH	274 x 90 x 293 mm

- Rebars, steel and welded meshes, padlocks, seals, chains
Tondini, reti metalliche ed elettrosaldate, lucchetti, sigilli, catene
- Ideal for building and industrial works
Ideale per edilizia e industria
- Small dimensions allow to reach confined places
Le dimensioni ridotte permettono di raggiungere posti stretti

Hose included (3 m - 700 bar)
Tubazione inclusa (3 m - 700 bar)**T28N**

Corded cutter - Cesoia a filo

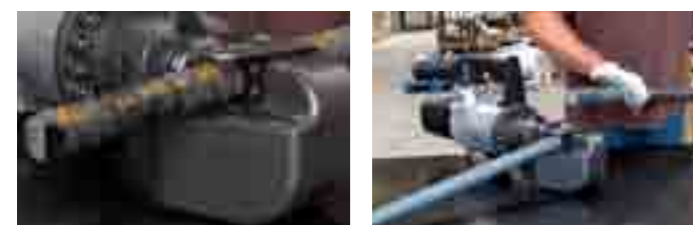
T28N: 230V 150.02016 - **120V** 150.02648**T32N****T32N: 230V** 150.01916 - **120V (US plug)** 150.01926

Cutting capacity	Capacità di taglio	Ø 28 mm (Rm: 65 daN/mm ²)
Cutting force	Forza di taglio	382 kN (38.9 t)
Working pressure	Pressione d'esercizio	60 MPa (600 bar)
Power supply	Alimentazione	230 - 120 Vac
Motor	Motore	230V: 1400 W - 50 Hz - 6.8 A 120V: 1300 W - 60 Hz - 11 A
Cylinder	Cilindro	Single acting Semplice effetto
Weight	Peso	16,9 kg
Dimensions LxWxH	Dimensioni LxPxH	479 x 149 x 255 mm

Cutting capacity	Capacità di taglio	Ø 32 mm (Rm: 70 daN/mm ²)
Cutting force	Forza di taglio	486 kN (49.6 t)
Working pressure	Pressione d'esercizio	70 MPa (700 bar)
Power supply	Alimentazione	230 - 120 Vac
Motor	Motore	230V: 1400 W - 50 Hz - 6.8 A 120V: 1300 W - 60 Hz - 11 A
Cylinder	Cilindro	Single acting Semplice effetto
Weight	Peso	27 kg
Dimensions LxWxH	Dimensioni LxPxH	557 x 175 x 320 mm

- Rebars, rods, threaded bars
Tondini, barre tonde, barre filettate

- Small dimensions allow to reach confined places
Le dimensioni ridotte permettono di raggiungere posti stretti

Accessories Accessori

Lifting hook	Gancio di sollevamento	110.03666
--------------	------------------------	------------------

**T18 ELECTRIC DRIVE / AZIONAMENTO ELETTRICO**

Cutter - Cesoia

150.01148



Cutting capacity	Capacità di taglio	Ø 18 mm (Rm: 70 daN/mm ²)
Cutting force	Forza di taglio	166.7 kN (17 t)
Working pressure	Pressione d'esercizio	70 MPa (700 bar)
Cylinder	Cilindro	Double acting Doppio effetto
Weight	Peso	6 kg
Dimensions LxWxH	Dimensioni LxPxH	273 x 103 x 249 mm

- Rebars, rods, threaded bars
Tondini, barre tonde, barre filettate
- Ideal for building and industrial works
Ideale per edilizia e industria
- Small dimensions allow to reach confined places
Le dimensioni ridotte permettono di raggiungere posti stretti

Hose included (3 m - 700 bar)
Tubazione inclusa (3 m - 700 bar)

T22 ELECTRIC DRIVE / AZIONAMENTO ELETTRICO

Cutter - Cesoa

155.00070



Cutting capacity	Capacità di taglio	Ø 22 mm (Rm: 70 daN/mm²)
Cutting force	Forza di taglio	304 kN (31 t)
Working pressure	Pressione d'esercizio	70 MPa (700 bar)
Cylinder	Cilindro	Double acting Doppio effetto
Weight	Peso	9 kg
Dimensions LxWxH	Dimensioni LxPxH	325 x 137 x 229 mm

- Rebars, rods, threaded bars
Tondini, barre tonde, barre filettate
- Ideal for building and industrial works
Ideale per edilizia e industria
- Small dimensions allow to reach confined places
Le dimensioni ridotte permettono di raggiungere posti stretti

Hose included (3 m- 700 bar)
Tubazione inclusa (3 m- 700 bar)

T30 ELECTRIC DRIVE / AZIONAMENTO ELETTRICO

Cutter - Cesoa

150.02619



Cutting capacity	Capacità di taglio	Ø 30 mm (Rm: 70 daN/mm²)
Cutting force	Forza di taglio	445 kN (44.5 t)
Working pressure	Pressione d'esercizio	70 MPa (700 bar)
Cylinder	Cilindro	Double acting Doppio effetto
Weight	Peso	21 kg
Dimensions LxWxH	Dimensioni LxPxH	478 x 183 x 222 mm

- Rebars, rods, threaded bars
Tondini, barre tonde, barre filettate
- Ideal for building and industrial works
Ideale per edilizia e industria
- Small dimensions allow to reach confined places
Le dimensioni ridotte permettono di raggiungere posti stretti

Hose included (3 m- 700 bar)
Tubazione inclusa (3 m- 700 bar)

T35/63 ELECTRIC DRIVE / AZIONAMENTO ELETTRICO

Cutter - Cesoa

150.01971



Cutting capacity	Capacità di taglio	Ø 35 mm (Rm: 70 daN/mm²)
Cutting force	Forza di taglio	606 kN (61.8 t)
Working pressure	Pressione d'esercizio	70 MPa (700 bar)
Cylinder	Cilindro	Double acting Doppio effetto
Weight	Peso	48 kg
Dimensions LxWxH	Dimensioni LxPxH	565 x 213 x 259 mm

- Rebars, rods, threaded bars
Tondini, barre tonde, barre filettate
- Sprues and aluminium castings
Materozze e fusioni di alluminio
- Ideal for building and industrial works
Ideale per edilizia e industria
- Very robust and able to cut diameters up to 35 mm
Molto robusta e in grado di tagliare grossi spessori
- Equipped with lifting hook
Dotata di gancio per sollevamento

Hose included (3 m- 700 bar)
Tubazione inclusa (3 m- 700 bar)

T50N ELECTRIC DRIVE / AZIONAMENTO ELETTRICO

Cutter - Cesoa

150.03636



Cutting capacity	Capacità di taglio	Ø 52 mm (Rm: 70 daN/mm²)
Cutting force	Forza di taglio	1078 kN (110 t)
Working pressure	Pressione d'esercizio	70 MPa (700 bar)
Cylinder	Cilindro	Double acting Doppio effetto
Weight	Peso	120 kg
Dimensions LxWxH	Dimensioni LxPxH	765 x 246 x 311 mm

- Rebars, rods, threaded bars
Tondini, barre tonde, barre filettate
- Sprues and aluminium castings
Materozze e fusioni di alluminio
- Ideal for building and industrial works
Ideale per edilizia e industria
- Very robust and able to cut diameters up to 52 mm
Molto robusta e in grado di tagliare grossi spessori
- Equipped with lifting hook
Dotata di gancio per sollevamento

Hose included (3 m- 700 bar)
Tubazione inclusa (3 m- 700 bar)

RD8-20 - 18V

Battery-powered straightener - Raddrizzatrice a batteria

150.03302



Straightening capacity	Capacità di raddrizzatura	Ø 8 ÷ 20 mm (Rm: 70 daN/mm ²)
Adjustable stroke	Corsa regolabile	✓
Straightening force	Forza di raddrizzatura	78 kN (8 t)
Working pressure	Pressione d'esercizio	40 MPa (400 bar)
Power supply	Alimentazione	Battery - Batteria
Motor	Motore	18V
Cylinder	Cilindro	Double acting Doppio effetto
Weight*	Peso*	8.5 kg
Dimensions LxWxH*	Dimensioni LxPxH*	460 x 167 x 319 mm

*Dimensions and weight w/o battery / Dimensioni e peso senza batteria

- Rebars, rods
Tondini, barre tonde
- Long battery life
Batteria a lunga durata
- Ideal for building and industrial works
Ideale per edilizia e industria
- Lightweight
Leggera
- Small dimensions allow to reach confined places
Le dimensioni ridotte permettono di raggiungere posti stretti

Battery and charger not included
Batteria e caricabatteria non inclusa**MU16P - 18V**

Battery-powered bender - Piegatrice a batteria

150.03266



Bending capacity	Capacità di piegatura	Ø 16 mm (Rm: 70 daN/mm ²)
Bending force	Forza di piegatura	103 kN (10.5 t)
Working pressure	Pressione d'esercizio	40 MPa (400 bar)
Power supply	Alimentazione	Battery - Batteria
Motor	Motore	18V
Cylinder	Cilindro	Single acting Semplice effetto
Weight*	Peso*	10.7 kg
Dimensions LxWxH*	Dimensioni LxPxH*	564 x 191 x 299 mm

*Dimensions and weight w/o battery / Dimensioni e peso senza batteria

- Rebars, rods
Tondini, barre tonde
- Long battery life
Batteria a lunga durata
- Ideal for building and industrial works
Ideale per edilizia e industria
- Lightweight
Leggera
- Small dimensions allow to reach confined places
Le dimensioni ridotte permettono di raggiungere posti stretti

Battery and charger not included
Batteria e caricabatteria non inclusa**MU16P**

Corded bender - Piegatrice a filo

230V 150.01100 - 120V 150.02525



Bending capacity	Capacità di piegatura	Ø 16 mm (Rm: 70 daN/mm ²)
Bending force	Forza di piegatura	103 kN (10.5 t)
Working pressure	Pressione d'esercizio	40 MPa (400 bar)
Power supply	Alimentazione	Mains Rete elettrica
Motor	Motore	230V: 1100 W - 50 Hz - 5.3 A 120V: 1100 W - 60 Hz - 9.2 A
Cylinder	Cilindro	Single acting Semplice effetto
Weight	Peso	12 kg
Dimensions LxWxH	Dimensioni LxPxH	497 x 131 x 225 mm

- Rebars, rods
Tondini, barre tonde
- Ideal for building and industrial works
Ideale per edilizia e industria
- Small dimensions allow to reach confined places
Le dimensioni ridotte permettono di raggiungere posti stretti

PR16-32DE

Corded bender/straightener - Piegatrice/raddrizzatrice a filo

230V 150.02904 - 120V 150.02905



Bending capacity	Capacità di piegatura	Ø 32 mm (Rm: 70 daN/mm ²)
Bending force	Forza di piegatura	243 kN (24.8 t)
Working pressure	Pressione d'esercizio	55 MPa (550 bar)
Power supply	Alimentazione	Mains Rete elettrica
Motor	Motore	230V: 1100 W - 50 Hz - 5.3 A 120V: 1100 W - 60 Hz - 9.2 A
Head rotation	Rotazione testa	180°
Cylinder	Cilindro	Double acting Doppio effetto
Weight	Peso	26.4 kg
Dimensions LxWxH	Dimensioni LxPxH	613 x 293 x 225 mm

Accessories - Accessori

Bending roller Ø 22 ÷ 26	Rullo piega Ø 22 ÷ 26	110.06995
Bending roller Ø 16 ÷ 20	Rullo piega Ø 16 ÷ 20	110.06996

BAR DIAMETER DIAMETRO BARRA	ROLLERS DIAMETER DIAMETRO BOCCOLE	CAM DIAMETER DIAMETRO CAMMA	BAR D./CAM D. RATIO RAPPORTO D. BARRA/D. CAMMA
Ø 16 ÷ 20 mm	Ø 68 mm	Ø 128 mm	8 - 6.4
Ø 22 ÷ 26 mm	Ø 56 mm	Ø 128 mm	5.8 - 5
Ø 28 ÷ 32 mm	Ø 44 mm	Ø 128 mm	4.6 - 4

R16

Straightener - Raddrizzatrice

R16: 150.00607

R16+ (Reinforced version - Versione maggiorata)

R16+: 155.00048



- Rebars, rods
Tondini, barre tonde

- Ideal for building and industrial works
Ideale per edilizia e industria

R16

Bending capacity	Capacità di piegatura	Ø 16 mm (Rm: 70 daN/mm ²)
Bending force	Forza di piegatura	62.8 kN (6.4 t)
Working pressure	Pressione d'esercizio	40 MPa (400 bar)
Cylinder	Cilindro	Double / Doppio
Weight	Peso	6 kg
Dimensions LxWxH	Dimensioni LxPxH	369 x 238 x 215 mm

R16+

Bending capacity	Capacità di piegatura	Ø 16 mm (Rm: 70 daN/mm ²)
Bending force	Forza di piegatura	62.8 kN (6.4 t)
Working pressure	Pressione d'esercizio	40 MPa (400 bar)
Cylinder	Effetto	Double acting Doppio effetto
Weight	Peso	11 kg
Dimensions LxWxH	Dimensioni LxPxH	367 x 235 x 247 mm

Hose included (3 m - 400 bar)
Tubazione inclusa (3 m - 400 bar)

HPU to suit - Centralina consigliata: **VDS700 G28**: 150.00667
CB700 L4: 150.00815

RD8-20

Straightener - Raddrizzatrice

RD8-20: 150.02022

RD20-32

RD20-32: 150.02036



- Rebars, rods
Tondini, barre tonde

- Ideal for building and industrial works
Ideale per edilizia e industria

RD8-20

Bending capacity	Capacità di piegatura	Ø 8÷20 mm (Rm: 70 daN/mm ²)
Adjustable stroke	Corsa regolabile	✓
Bending force	Forza di piegatura	49 kN (5 t)
Working pressure	Pressione d'esercizio	40 MPa (400 bar)
Cylinder	Cilindro	Double acting Doppio effetto
Weight	Peso	9.4 kg
Dimensions LxWxH	Dimensioni LxPxH	337 x 155 x 230 mm

RD20-32

Bending capacity	Capacità di piegatura	Ø 20÷32 mm (Rm: 70 daN/mm ²)
Adjustable stroke	Corsa regolabile	✓
Bending force	Forza di piegatura	112.8 kN (11.5 t)
Working pressure	Pressione d'esercizio	40 MPa (400 bar)
Cylinder	Cilindro	Double acting Doppio effetto
Weight	Peso	15.4 kg
Dimensions LxWxH	Dimensioni LxPxH	394 x 259 x 235 mm

Hose included (3 m - 400 bar)
Tubazione inclusa (3 m - 400 bar)

HPU to suit - Centralina consigliata: **VDS700 G28**: 150.00667
CB700 L4: 150.00815

ROLLERS ASSEMBLY INSTRUCTION

ISTRUZIONI OPERATIVE PER L'ASSEMBLAGGIO DELLE BOCCOLE

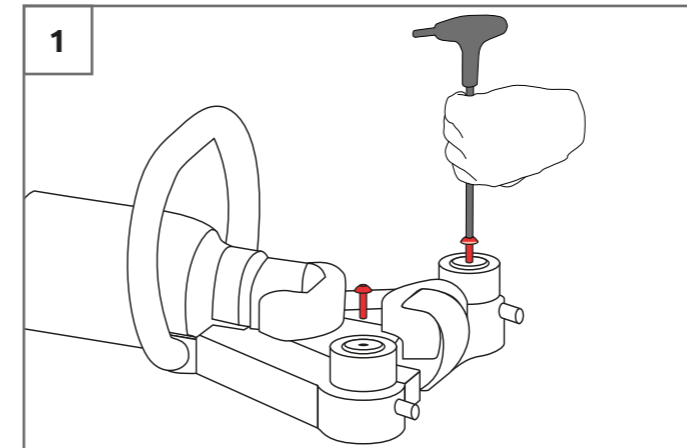

Unscrew the screws on the rollers
Svitare le viti poste sulle boccole

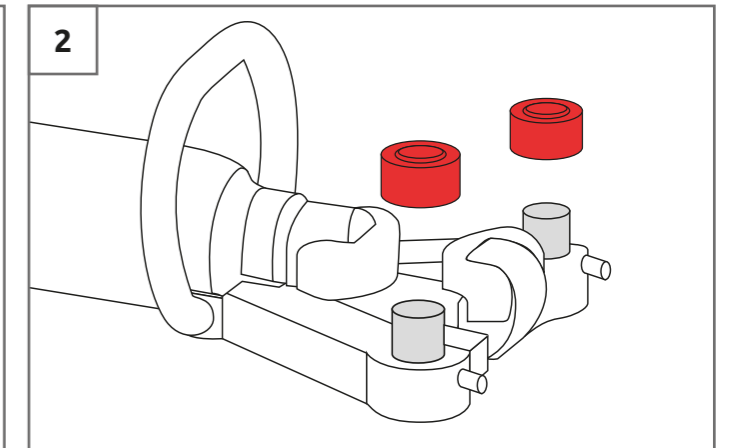

Remove the rollers
Togliere le boccole

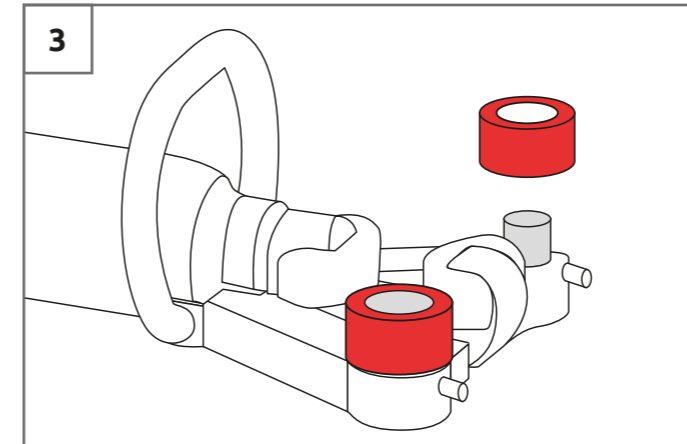

Insert the new rollers
Inserire le nuove boccole

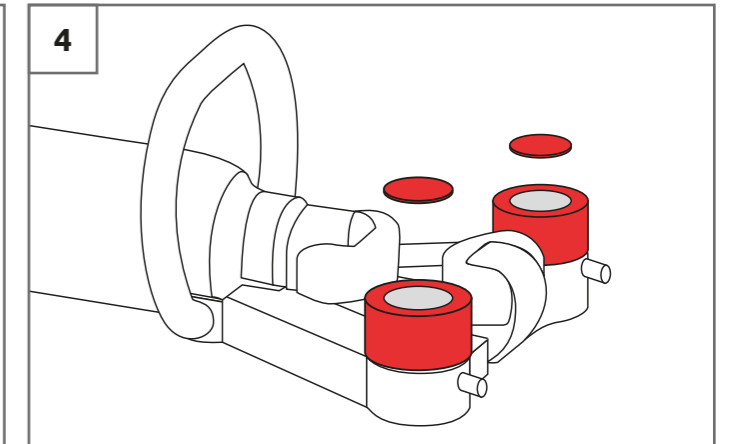

Place the protection cap on the rollers
Posizionare il tappo di protezione sopra le boccole

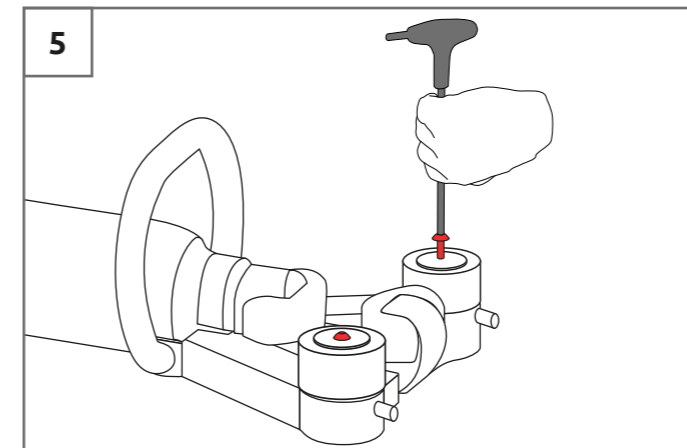

Tighten the screws on the rollers
Avvitare le viti poste sulle boccole

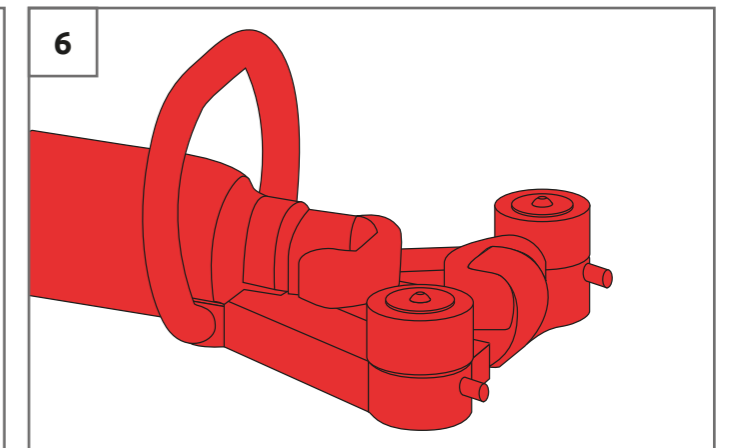

Test the tool
Testare l'attrezzo

02



MULTI-TOOLS ATTREZZI MULTIFUNZIONE

MU22N

Corded multifunction tool - Utensile multifunzione a filo

230V 150.01952 - 120V (US plug) 150.01909 - 110V (UK plug) 150.03002



Cutting/bending capacity	Capacità di taglio/piega	see p. 25/26 - vedi p. 25/26
Force	Forza	235 kN (24 t)
Working pressure	Pressione d'esercizio	58 MPa (580 bar)
Power supply	Alimentazione	Mains Rete elettrica
Motor	Motore	230V: 1400 W - 50 Hz - 6.8 A 120V: 1100 W - 60 Hz - 9.2 A
Cylinder	Effetto	Single acting Semplice effetto
Weight	Peso	13.7 kg
Dimensions LxWxH	Dimensioni LxPxH	402 x 146 x 236 mm

- Versatile tool: cutting, bending
Utensile versatile: taglia, piega
- Rebars, rods, threaded bars
Tondini, barre tonde, barre filettate
- Cables and ropes
Cavi e funi
- Stone cutting
Taglio sassi
- Ideal for building and industrial works
Ideale per edilizia e industria
- Small dimensions allow to reach confined places
Le dimensioni ridotte permettono di raggiungere posti stretti

MU26N

Corded multifunction tool - Utensile multifunzione a filo

230V 150.01891 - 120V (US plug) 150.01911 - 110V (UK plug) 150.02060



Cutting/bending capacity	Capacità di taglio/piega	see p. 25/26 - vedi p. 25/26
Force	Forza	353 kN (36 t)
Working pressure	Pressione d'esercizio	58 MPa (580 bar)
Power supply	Alimentazione	Mains Rete elettrica
Motor	Motore	230V: 1400 W - 50 Hz - 6.8 A 120V: 1100 W - 60 Hz - 9.2 A
Cylinder	Effetto	Single acting Semplice effetto
Weight	Peso	13.6 kg
Dimensions LxWxH	Dimensioni LxPxH	402 x 146 x 236 mm

- Versatile tool: cutting, bending
Utensile versatile: taglia, piega
- Rebars, rods, threaded bars
Tondini, barre tonde, barre filettate
- Ideal for building and industrial works
Ideale per edilizia e industria
- Small dimensions allow to reach confined places
Le dimensioni ridotte permettono di raggiungere posti stretti

DOUBLE ACTING VERSION - VERSIONE DOPPIO EFFETTO
MU26 DE: 230V 150.00149

**INTERCHANGEABLE HEADS*
TESTE INTERCAMBIABILI*****T22**Cutting head
Testa taglio
150.00117**T26**Cutting head
Testa taglio
150.00085**P22**Bending head
Testa piega
150.01915**P26**Bending head
Testa piega
150.01890

		T22	T26	P22	P26
Cutting/bending capacity	Capacità di taglio/piega	Ø 22 mm	Ø 26 mm	Ø 22 mm	Ø 26 mm
Weight	Peso	3.4 kg	4.7 kg	5.3 kg	7.9 kg
Dimensions	Dimensioni	135 x 112 x 118 mm	145 x 125 x 127 mm	193 x 90 x 110 mm	225 x 135 x 135 mm
TOOL	ATTREZZO	MU22	MU26	MU22	MU26

INTERCHANGEABLE HEADS* TESTE INTERCAMBIABILI*

TF32

Rope/cable cutting head
Testa taglio fune/cavo
150.00064



TS500

Stone cutting head
Testa taglio sassi
150.00106



TS500 +

Stone cutting head - oversized
Testa taglio sassi - maggiorata
150.00673

TR40

Straightening head
Testa raddrizzatrice
150.00061



TP120x12 DE

Flat bar cutting head
Testa taglia piatto
155.00056



		TF32	TS500	TS500 +	TR40	TP120x12 DE
Cutting/bending capacity	Capacità di taglio/piega	Ø 32 mm	520 x 215 mm	520 x 320 mm	Ø 30 mm	120 x 12 mm
Weight	Peso	4.5 kg	153 kg	157 kg	4.5 kg	21 kg
Dimensions	Dimensioni	145 x 90 x 120 mm	1090 x 400 x 1135 mm	1090 x 400 x 1260 mm	270 x 150 x 90 mm	230 x 180 x 120 mm
TOOL	ATTREZZO	MU22	MU22	MU22	MU22	MU26 DE

ATTACHMENTS INSTALLATION GUIDE* ISTRUZIONI OPERATIVE PER MONTARE LE TESTE*

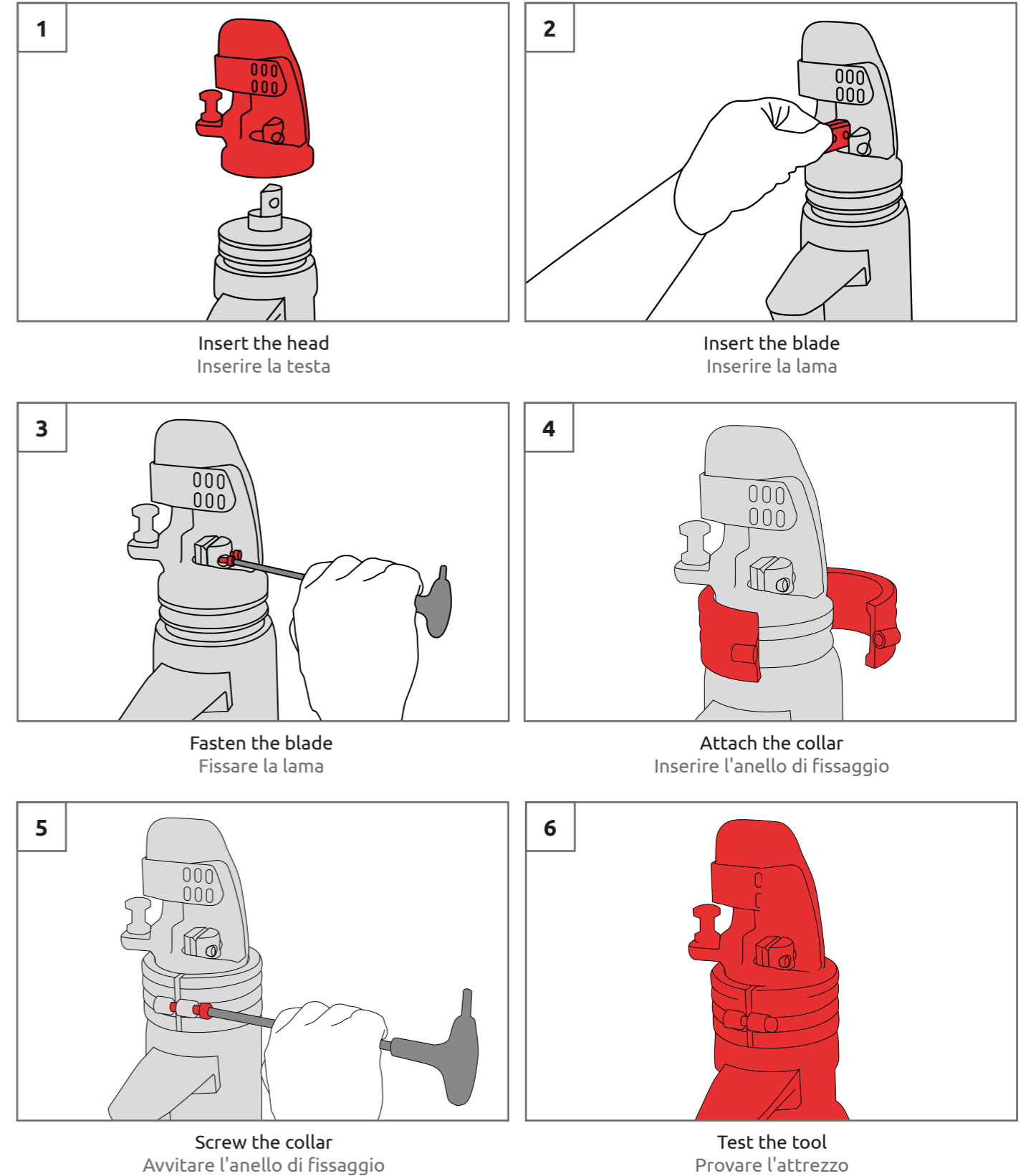

*The pictures refer to the T22 head
Le figure si riferiscono alla testa T22

103

A black and white photograph showing a person's hands operating a chain cutter. The person is wearing a dark long-sleeved shirt and white gloves. The chain cutter is a large, industrial-grade tool with a black handle and a silver-colored body. It is being used to cut through a thick, braided metal cable. The background is blurred, suggesting an outdoor or industrial setting. A large red number '103' is overlaid on the left side of the image, enclosed in a red L-shaped border.

**CHAIN CUTTERS TAGLIA CATENE
CABLE/ROPE CUTTERS TAGLIA CAVI/FUNI**

TC26M

Corded chain cutter - Cesovia taglia catena a filo

230V 150.03646 - **120V** 150.03690

Cutting capacity	Capacità di taglio	Ø 26 mm (Grade 40 - Grado 40) Ø 16 mm (Grade 120 - Grado 120)
Cutting force	Forza di taglio	312 kN (31.8 t)
Working pressure	Pressione d'esercizio	55 MPa (550 bar)
Power supply	Alimentazione	Mains Rete elettrica
Motor	Motore	230V: 1100 W - 50 Hz - 5.3 A 120V: 1200 W - 60 Hz - 10 A
Cylinder	Effetto	Single acting Semplice effetto
Weight	Peso	24.8 kg
Dimensions LxWxH	Dimensioni LxPxH	600 x 154 x 235 mm

- Interchangeable blades for cutting chains with different diameters
Coltelli intercambiabili per tagliare catene di diverso diametro
- Ideal for building and industrial works
Ideale per edilizia e industria
- It can be placed anywhere thanks to its small weight and dimensions
Può essere posizionata ovunque grazie al peso e alle dimensioni contenute
- Equipped with safety cover
Dotata di coperchio protettivo
- Equipped with a release lever in the event of a piston jam
Dotata di leva di sblocco in caso di inceppamento del pistone

TC32DE

Corded chain cutter - Cesovia taglia catena a filo

230V 150.01944 - **120V** 150.02121

Cutting capacity	Capacità di taglio	Ø 32 mm (Grade 40 - Grado 40) Ø 18 mm (Grade 120 - Grado 120)
Cutting force	Forza di taglio	312 kN (31.8 t)
Working pressure	Pressione d'esercizio	55 MPa (550 bar)
Power supply	Alimentazione	Mains Rete elettrica
Motor	Motore	230V: 1400 W - 50 Hz - 6.8 A 120V: 1300 W - 60 Hz - 11 A
Cylinder	Effetto	Double acting Doppio effetto
Weight	Peso	43 kg
Dimensions LxWxH	Dimensioni LxPxH	700 x 192 x 321 mm

- Interchangeable blades for cutting chains with different diameters
Coltelli intercambiabili per tagliare catene di diverso diametro
- Ideal for building and industrial works
Ideale per edilizia e industria
- Designed for heavy-duty operations
Progettata per eseguire operazioni pesanti
- Equipped with safety cover
Dotata di coperchio protettivo
- Equipped with lifting hook
Dotata di gancio di sollevamento

TW19

Corded prestressed strand cutter - Cesovia taglia trefolo a filo

230V 150.00127 - **120V** 150.00623

Cutting capacity	Capacità di taglio	Ø 16 mm (Rm: 160 daN/mm²)
Cutting force	Forza di taglio	235 kN (24 t)
Working pressure	Pressione d'esercizio	58 MPa (580 bar)
Power supply	Alimentazione	Mains Rete elettrica
Motor	Motore	230V: 1400 W - 50 Hz - 6.8 A 120V: 1200 W - 60 Hz - 10 A
Cylinder	Effetto	Single acting Semplice effetto
Weight	Peso	15.9 kg
Dimensions LxWxH	Dimensioni LxPxH	480 x 170 x 256 mm

- Ideal for building and industrial works
Ideale per edilizia e industria
- It can be placed anywhere thanks to its small weight and dimensions
Può essere posizionata ovunque grazie al peso e alle dimensioni contenute
- Equipped with safety shield
Dotata di schermo protettivo
- Equipped with a release lever in the event of a piston jam
Dotata di leva di sblocco in caso di inceppamento del pistone

TW19 DE

Prestressed strand cutter - Taglia trefolo

150.02058



Cutting capacity	Capacità di taglio	Ø 16 mm (Rm: 160 daN/mm²)
Cutting force	Forza di taglio	208.9 kN (31.5 t)
Working pressure	Pressione d'esercizio	70 MPa (700 bar)
Cylinder	Effetto	Double acting Doppio effetto
Weight	Peso	12.8 kg
Dimensions LxWxH	Dimensioni LxPxH	364 x 137 x 265 mm

- Ideal for building and industrial works
Ideale per edilizia e industria
- Equipped with safety shield
Dotata di schermo protettivo
- Equipped with a release lever in the event of a piston jam
Dotata di leva di sblocco in caso di inceppamento del pistone

Hose included (3 m- 700 bar)
Tubazione inclusa (3 m- 700 bar)

TF32DE

Corded rope cutter - Cesovia taglia fune a filo

230V 150.02069 - 120V 150.03086



Cutting capacity	Capacità di taglio	Ø 32 mm
Cutting force	Forza di taglio	182 kN (18.6 t)
Working pressure	Pressione d'esercizio	55 MPa (550 bar)
Power supply	Alimentazione	Mains Rete elettrica
Motor	Motore	230V: 1100 W - 50 Hz - 5.3 A 120V: 1200 W - 60 Hz - 10 A
Cylinder	Effetto	Double acting Doppio effetto
Weight	Peso	15.2 kg
Dimensions LxWxH	Dimensioni LxPxH	550 x 185 x 256 mm

- Ideal for building and industrial works
Ideale per edilizia e industria
- Ideal for underground and telecom cables
Ideale per funi e cavi sotterranei e telefonici

**TF63**

Wire rope cutter - Cesovia taglia fune

150.02611



Cutting capacity	Capacità di taglio	Ø 63 mm
Cutting force	Forza di taglio	853 kN (87 t)
Working pressure	Pressione d'esercizio	70 MPa (700 bar)
Cylinder	Effetto	Double acting Doppio effetto
Weight	Peso	67 kg
Dimensions LxWxH	Dimensioni LxPxH	670 x 240 x 176 mm

- Ideal for building and industrial works
Ideale per edilizia e industria
- Ideal for underground and telecom cables
Ideale per funi e cavi sotterranei e telefonici

**TC55F42DE**

Corded cable/rope cutter - Cesovia taglia cavo/fune a filo

230V 150.02064 - 120V 150.02113



Cutting capacity	Capacità di taglio	Ø 55 mm (cable - cavo) Ø 42 mm (rope - fune)
Cutting force	Forza di taglio	340 kN (34.7 t)
Working pressure	Pressione d'esercizio	60 MPa (600 bar)
Power supply	Alimentazione	Mains Rete elettrica
Motor	Motore	230V: 1400 W - 50 Hz - 6.8 A 120V: 1200 W - 60 Hz - 10 A
Cylinder	Effetto	Double acting Doppio effetto
Weight	Peso	26 kg
Dimensions LxWxH	Dimensioni LxPxH	627 x 183 x 264 mm

- Ideal for building and industrial works
Ideale per edilizia e industria
- Ideal for underground and telephone cables
Ideale per funi e cavi sotterranei e telefonici

**TC90 - TC140 - TC180**

Cable cutter - Taglia cavi

TC90: 155.00023 - TC140: 150.01102 - TC180: 150.02086



- Ideal for industrial and demolition works
Ideale per industria e demolizione
- Designed for heavy-duty operations
Progettata per eseguire operazioni pesanti
- Equipped with lifting hook
Dotata di gancio di sollevamento

HPU to suit - Centralina consigliata:
CB700: 150.00804

Hose included (6 m - 700 bar)
Tubazione inclusa (6 m - 700 bar)

		TC90	TC140	TC180
Cutting capacity	Capacità di taglio	Ø 90 mm (electric cable - cavo elettrico)	Ø 140 mm (electric cable - cavo elettrico)	Ø 180 mm (electric cable - cavo elettrico)
Cutting force	Forza di taglio	550 kN (56.1 t)	550 kN (56.1 t)	792 kN (80.7 t)
Working pressure	Pressione d'esercizio	70 MPa (700 bar)	70 MPa (700 bar)	70 MPa (700 bar)
Cylinder	Effetto	Double acting Doppio effetto	Double acting Doppio effetto	Double acting Doppio effetto
Weight	Peso	80 kg	95 kg	160 kg
Dimensions LxWxH	Dimensioni LxPxH	751 x 150 x 252 mm	951 x 149 x 300 mm	1364 x 550 x 400 mm



04



PUNCHERS PUNZONATRICI
FLAT BAR CUTTERS TAGLIA BARRE PIATTE
NIBBLERS RODITRICI

PG22/60 DE - 18VBattery-powered puncher - Punzonatrice a batteria
150.03621

Punching capacity	Capacità di punzonatura	See p. 40 / Vedi p. 40
Max punch	Punzone max	Ø 22 mm
Punching force	Forza di punzonatura	147 kN (15 t)
Working pressure	Pressione d'esercizio	70 MPa (700 bar)
Power supply	Alimentazione	Battery - Batteria
Motor	Motore	18V
Cylinder	Effetto	Double acting Doppio effetto
Weight*	Peso*	13.5 kg
Dimensions LxWxH*	Dimensioni LxPxH*	580 x 127 x 278 mm

*Dimensions and weight w/o battery / Dimensioni e peso senza batteria

- Ideal for building and industrial works
Ideale per edilizia e industria
- Ideal for punching steel, copper, aluminium
Ideale per acciaio, rame, alluminio
- Double acting
Doppio effetto
- Small dimensions allow to reach confined places
Le dimensioni ridotte permettono di raggiungere posti stretti

Battery and charger not included
Batteria e caricabatteria non inclusa**PG22/120N DE - 18V**Battery-powered puncher - Punzonatrice a batteria
150.02567

Punching capacity	Capacità di punzonatura	See p. 40 / Vedi p. 40
Max punch	Punzone max	Ø 30 mm
Punching force	Forza di punzonatura	147 kN (15 t)
Working pressure	Pressione d'esercizio	70 MPa (700 bar)
Power supply	Alimentazione	Battery - Batteria
Motor	Motore	18V
Cylinder	Effetto	Double acting Doppio effetto
Weight*	Peso*	14.5 kg
Dimensions LxWxH*	Dimensioni LxPxH*	567 x 196 x 273 mm

*Dimensions and weight w/o battery / Dimensioni e peso senza batteria

- Ideal for building and industrial works
Ideale per edilizia e industria
- Ideal for punching steel, copper, aluminium
Ideale per acciaio, rame, alluminio
- Double acting
Doppio effetto
- Small dimensions allow to reach confined places
Le dimensioni ridotte permettono di raggiungere posti stretti

Accessories - Accessori

Punch adapter Ø 23 ÷ 30 mm	Adattatore punzone Ø 23 ÷ 30 mm	110.05866
----------------------------	---------------------------------	-----------

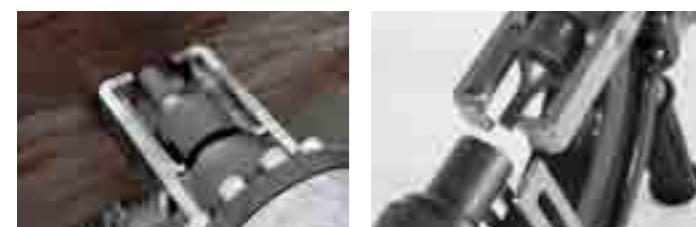
Battery and charger not included
Batteria e caricabatteria non inclusa**PB500 DE - 18V**Battery-powered puncher - Punzonatrice a batteria
150.03618

Punching capacity	Capacità di punzonatura	See p. 41 / Vedi p. 41
Max punch	Punzone max	Ø 30 mm
Punching force	Forza di punzonatura	206 kN (21 t)
Working pressure	Pressione d'esercizio	55 MPa (550 bar)
Power supply	Alimentazione	Battery - Batteria
Motor	Motore	18V
Cylinder	Effetto	Double acting Doppio effetto
Weight*	Peso*	13.9 kg
Dimensions LxWxH*	Dimensioni LxPxH*	557 x 202 x 271 mm

*Dimensions and weight w/o battery / Dimensioni e peso senza batteria

- Ideal for building and industrial works
Ideale per edilizia e industria
- Ideal for punching steel, copper, aluminium
Ideale per acciaio, rame, alluminio
- Double acting
Doppio effetto
- Small dimensions allow to reach confined places
Le dimensioni ridotte permettono di raggiungere posti stretti

Accessories - Accessori

Punch adapter Ø 23 ÷ 30 mm	Adattatore punzone Ø 23 ÷ 30 mm	110.05866
----------------------------	---------------------------------	-----------

Battery and charger not included
Batteria e caricabatteria non inclusa**PG22/60 DE**Corded puncher - Punzonatrice a filo
230V 150.00631 - 120V 150.02588

Punching capacity	Capacità di punzonatura	See p. 40 / Vedi p. 40
Max punch	Punzone max	Ø 22 mm
Punching force	Forza di punzonatura	147 kN (15 t)
Working pressure	Pressione d'esercizio	70 MPa (700 bar)
Power supply	Alimentazione	Mains Rete elettrica
Motor	Motore	230V: 1100 W - 50 Hz - 5.3 A 120V: 1200 W - 60 Hz - 10 A
Cylinder	Effetto	Double acting Doppio effetto
Weight	Peso	13.6 kg
Dimensions LxWxH	Dimensioni LxPxH	625 x 113 x 202 mm

- Ideal for building and industrial works
Ideale per edilizia e industria
- Ideal for punching steel, copper, aluminium
Ideale per acciaio, rame, alluminio
- Double acting
Doppio effetto
- Small dimensions allow to reach confined places
Le dimensioni ridotte permettono di raggiungere posti stretti



PG22/120N DE

Corded puncher - Punzonatrice a filo

230V 150.02506 - 120V 150.02783

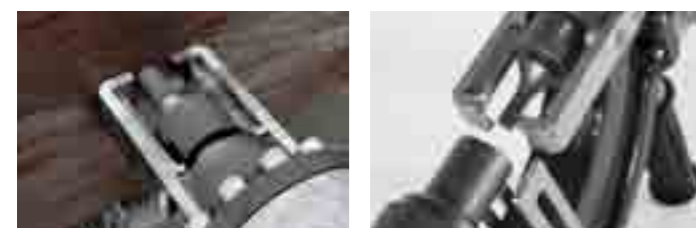

Punching capacity	Capacità di punzonatura	See p. 40 / Vedi p. 40
Max punch	Punzone max	Ø 22 mm
Punching force	Forza di punzonatura	147 kN (15 t)
Working pressure	Pressione d'esercizio	70 MPa (700 bar)
Power supply	Alimentazione	Mains Rete elettrica
Motor	Motore	230V: 1100 W - 50 Hz - 5.3 A 120V: 1200 W - 60 Hz - 10 A
Cylinder	Effetto	Double acting Doppio effetto
Weight	Peso	14 kg
Dimensions LxWxH	Dimensioni LxPxH	612 x 118 x 274 mm

- Ideal for building and industrial works
Ideale per edilizia e industria
- Ideal for punching steel, copper, aluminium
Ideale per acciaio, rame, alluminio
- Double acting
Doppio effetto
- Small dimensions allow to reach confined places
Le dimensioni ridotte permettono di raggiungere posti stretti

Accessories - Accessori

Punch adapter Ø 23 ÷ 30 mm	Adattatore punzone Ø 23 ÷ 30 mm	110.05866
----------------------------	---------------------------------	-----------

PZN28DE

Corded puncher - Punzonatrice a filo

• PROTRUDING DIE/MATRICE SPORGENTE: 230V 150.01972 - 120V 150.03044

• FLAT DIE/MATRICE PIANA: 230V 150.01963 - 120V 150.02384



Punching capacity	Capacità di punzonatura	See p. 41 / Vedi p. 41
Max punch	Punzone max	Ø 30 mm
Punching force	Forza di punzonatura	275 kN (28 t)
Working pressure	Pressione d'esercizio	55 MPa (550 bar)
Power supply	Alimentazione	Mains Rete elettrica
Motor	Motore	230V: 1400 W - 50 Hz - 6.8 A 120V: 1200 W - 60 Hz - 10 A
Cylinder	Effetto	Double acting Doppio effetto
Weight	Peso	28.6 kg (150.01972 - 150.03044) 25.4 kg (150.01963 - 150.02384)
Dimensions LxWxH	Dimensioni LxPxH	645 x 229 x 348 mm

- Ideal for building and industrial works
Ideale per edilizia e industria
- Ideal for punching steel, copper, aluminium
Ideale per acciaio, rame, alluminio
- Double acting
Doppio effetto

P35/110DE

Puncher - Punzonatrice

150.00653



Punching capacity	Capacità di punzonatura	See p. 42 / Vedi p. 42
Max punch	Punzone max	Ø 30 mm
Punching force	Forza di punzonatura	431.5 kN (44 t)
Working pressure	Pressione d'esercizio	70 MPa (700 bar)
Cylinder	Effetto	Double acting Doppio effetto
Weight	Peso	55 kg
Dimensions LxWxH	Dimensioni LxPxH	352 x 152 x 258 mm

HPU to suit - Centralina consigliata:
CB700: 150.00804

- Ideal for building and industrial works
Ideale per edilizia e industria
- Designed for heavy-duty operations
Progettata per eseguire operazioni pesanti
- Ideal for punching steel, copper, aluminium
Ideale per acciaio, rame, alluminio
- Double acting
Doppio effetto

Hose included (6 m - 700 bar)
Tubazione inclusa (6 m - 700 bar)

PZC35/150DE

Puncher - Punzonatrice

155.00057



Punching capacity	Capacità di punzonatura	See p. 42 / Vedi p. 42
Max punch	Punzone max	Ø 35 mm
Punching force	Forza di punzonatura	784.5 kN (80 t)
Working pressure	Pressione d'esercizio	70 MPa (700 bar)
Cylinder	Effetto	Double acting Doppio effetto
Weight	Peso	145 kg
Dimensions LxWxH	Dimensioni LxPxH	425 x 200 x 744 mm

HPU to suit - Centralina consigliata:
CB700: 150.00804

- Ideal for building and industrial works
Ideale per edilizia e industria
- Designed for heavy-duty operations
Progettata per eseguire operazioni pesanti
- Ideal for punching steel, copper, aluminium
Ideale per acciaio, rame, alluminio
- Double acting
Doppio effetto

Hose included (6 m - 700 bar)
Tubazione inclusa (6 m - 700 bar)

PUNCHING CAPACITY TABLE TABELLA CAPACITÀ DI PUNZONATURA

PG22/60DE

Ultimate tensile strength
Resistenza del materiale
R= 36 daN/mm²

Hole - Foro (mm) Ø	Thickness - Spessore (mm)
4	4
5	5
6	6
7	7
8	8
9	9
10	10
11	9
12	8
13	8
14	7
15	7
16	6
17	6
18	5
19	5
20	5
21	5
22	4

Ultimate tensile strength
Resistenza del materiale
R= 42 daN/mm²

Hole - Foro (mm) Ø	Thickness - Spessore (mm)
4	4
5	5
6	6
7	7
8	8
9	9
10	9
11	8
12	7
13	6
14	6
15	6
16	5
17	5
18	5
19	4
20	4
21	4
22	4

Ultimate tensile strength
Resistenza del materiale
R= 51 daN/mm²

Hole - Foro (mm) Ø	Thickness - Spessore (mm)
4	4
5	5
6	6
7	7
8	8
9	8
10	7
11	6
12	6
13	5
14	5
15	4
16	4
17	4
18	4
19	3
20	3
21	3
22	3

PG22/120NDE

Ultimate tensile strength
Resistenza del materiale
R= 36 daN/mm²

Hole - Foro (mm) Ø	Thickness - Spessore (mm)
4	4
5	5
6	6
7	7
8	8
9	9
10	10
11	9
12	8
13	8
14	7
15	7
16	6
17	6
18	5
19	5
20	5
21	5
22	4
23	4
24	4
25	4
26	4
27	3
28	3
29	3
30	3

Ultimate tensile strength
Resistenza del materiale
R= 42 daN/mm²

Hole - Foro (mm) Ø	Thickness - Spessore (mm)
4	4
5	5
6	6
7	7
8	8
9	9
10	9
11	8
12	7
13	6
14	6
15	6
16	5
17	5
18	5
19	4
20	4
21	4
22	4
23	3
24	3
25	3
26	3
27	3
28	3
29	3
30	3

Ultimate tensile strength
Resistenza del materiale
R= 51 daN/mm²

Hole - Foro (mm) Ø	Thickness - Spessore (mm)
4	4
5	5
6	6
7	7
8	8
9	8
10	7
11	6
12	6
13	5
14	5
15	4
16	4
17	4
18	4
19	3
20	3
21	3
22	3
23	3
24	3
25	2
26	2
27	2
28	2
29	2
30	2

PB500DE

Ultimate tensile strength
Resistenza del materiale
R= 36 daN/mm²

Hole - Foro (mm) Ø	Thickness - Spessore (mm)
4	4
5	5
6	6
7	7
8	8
9	9
10	10
11	11
12	12
13	13
14	13
15	12
16	11
17	10
18	10
19	9
20	9
21	8
22	8
23	8
24	7
25	7
26	7
27	6
28	6
29	6
30	6

Ultimate tensile strength
Resistenza del materiale
R= 42 daN/mm²

Hole - Foro (mm) Ø	Thickness - Spessore (mm)
4	4
5	5
6	6
7	7
8	8
9	9
10	10
11	11
12	12
13	12
14	11
15	10
16	9
17	9
18	8
19	8
20	7
21	7
22	7
23	6
24	6
25	6
26	6
27	5
28	5
29	5
30	5

Ultimate tensile strength
Resistenza del materiale
R= 51 daN/mm²

Hole - Foro (mm) Ø	Thickness - Spessore (mm)
4	4
5	5
6	6
7	7
8	8
9	9
10	10
11	11
12	10
13	10
14	9
15	8
16	8
17	7
18	7
19	6
20	6
21	6
22	5
23	5
24	5
25	5
26	5
27	4
28	4
29	4
30	4

PZN28DE FLAT DIE - MATRICE PIANA / PROTRUDING DIE - MATRICE SPORGENTE

Ultimate tensile strength
Resistenza del materiale
R= 36 daN/mm²

Hole - Foro (mm) Ø	Thickness - Spessore (mm)
4	4
5	5
6	6
7	7
8	8
9	9
10	10
11	11
12	12
13	13
14	14
15	15
16	15
17	14
18	13
19	13
20	12
21	11
22	11
23	10
24	10
25	9
26	9
27	9
28	8
29	8
30	8

Ultimate tensile strength
Resistenza del materiale
R= 42 daN/mm²

Hole - Foro (mm) Ø	Thickness - Spessore (mm)
4	4
5	5
6	6
7	7
8	8
9	9
10	10
11	11
12	12
13	13
14	14
15	14
16	13
17	12
18	11
19	11
20	10
21	10
22	9
23	9
24	8
25	8
26	8
27	7
28	7
29	7
30	7

Ultimate tensile strength
Resistenza del materiale
R= 51 daN/mm²

Hole - Foro (mm) Ø	Thickness - Spessore (mm)
4	4
5	5
6	6
7	7
8	8
9	9
10	10
11	11
12	12
13	13
14	12
15	11
16	10
17	10
18	9
19	9
20	8
21	8
22	7
23	7
24	7
25	6
26	6
27	6
28	6
29	6
30	5

P35/110DE

Ultimate tensile strength
Resistenza del materiale
R= 36 daN/mm²

Hole - Foro (mm) Ø	Thickness - Spessore (mm)
4	4
5	5
6	6
7	7
8	8
9	9
10	10
11	11
12	12
13	13
14	14
15	15
16	16
17	17
18	18
19	19
20	19
21	18
22	17
23	16
24	16
25	15
26	14
27	14
28	13
29	13
30	12

Ultimate tensile strength
Resistenza del materiale
R= 42 daN/mm²

Hole - Foro (mm) Ø	Thickness - Spessore (mm)
4	4
5	5
6	6
7	7
8	8
9	9
10	10
11	11
12	11
13	11
14	11
15	11
16	11
17	11
18	11
19	11
20	10
21	10
22	9
23	9
24	8
25	8
26	8
27	7
28	7
29	7
30	7

Ultimate tensile strength
Resistenza del materiale
R= 51 daN/mm²

Hole - Foro (mm) Ø	Thickness - Spessore (mm)
4	4
5	5
6	6
7	7
8	8
9	9
10	10
11	11
12	12
13	13
14	14
15	15
16	16
17	16
18	15
19	14
20	13
21	13
22	12
23	11
24	11
25	10
26	10
27	10
28	9
29	9
30	9

PZC35/150DE

Ultimate tensile strength
Resistenza del materiale
R= 36 daN/mm²

Hole - Foro (mm) Ø	Thickness - Spessore (mm)
4	4
5	5
6	6
7	7
8	8
9	9
10	10
11	11
12	12
13	13
14	14
15	15
16	16
17	17
18	18
19	19
20	20
21	21
22	22
23	23
24	24
25	25
26	26
27	26
28	25
29	24
30	23
31	22
32	22
33	21
34	20
35	20

Ultimate tensile strength
Resistenza del materiale
R= 42 daN/mm²

Hole - Foro (mm) Ø	Thickness - Spessore (mm)
4	4
5	5
6	6
7	7
8	8
9	9
10	10
11	11
12	12
13	13
14	14
15	15
16	16
17	17
18	18
19	19
20	20
21	21
22	22
23	23
24	24
25	24
26	23
27	22
28	21
29	20
30	20
31	19
32	18
33	18
34	17
35	17

Ultimate tensile strength
Resistenza del materiale
R= 51 daN/mm²

Hole - Foro (mm) Ø	Thickness - Spessore (mm)
4	4
5	5
6	6
7	7
8	8
9	9
10	10
11	11
12	12
13	13
14	14
15	15
16	16
17	17
18	18
19	19
20	20
21	21
22	22
23	21
24	20
25	19
26	19
27	18
28	17
29	17
30	16
31	16
32	15
33	15
34	14
35	14

PUNCHER HEADS DIMENSIONS DIMENSIONI TESTE PUNZONATRICI

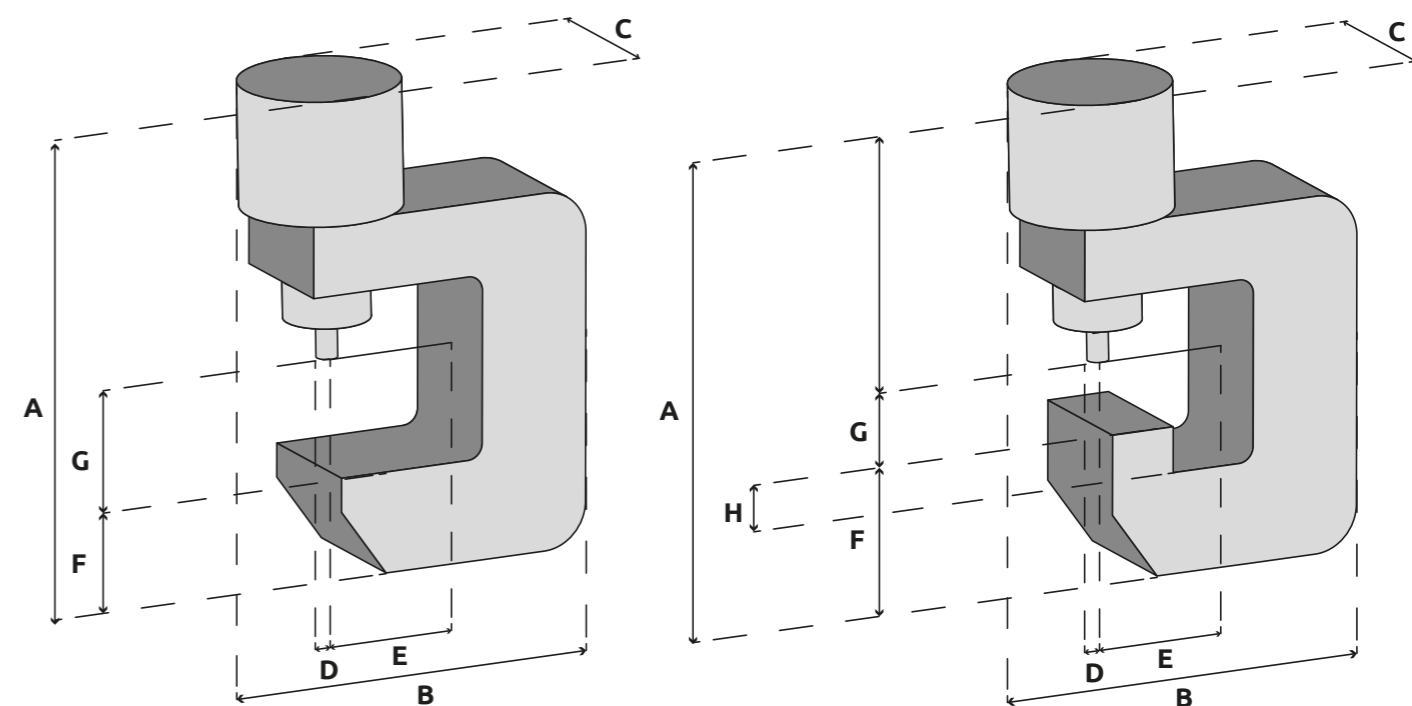

SIZES MISURE (mm)	A	B	C	D	E	F	G	H
PG 22/60 DE	217	178	40	25	70	109	15	43
PG 22/120 DE	204	250	40	27.5	120	96	15	/
PB 500	216	172	53	22.5	50	111	16	52
PZN 28 DE	230	180	65	29	59	89	16	/
PZN 28 DE1972	280	195	65	24.5	57	143	12	52
P 35/110 DE	265	342	100	34.5	110	110	25	/
PZ C35/150 DE	415	410	120	35	150	173	35	/

TP50

Corded flat bar cutter - Cesovia taglia piatto a filo

230V 150.00606 - 120V 150.02736



Cutting capacity	Capacità di taglio	50 x 17 mm
Cutting force	Forza di taglio	265 kN (27 t)
Working pressure	Pressione d'esercizio	60 MPa (600 bar)
Power supply	Alimentazione	Mains Rete elettrica
Motor	Motore	230V: 1400 W - 50 Hz - 6.8 A 120V: 1200 W - 60 Hz - 10 A
Cylinder	Effetto	Single acting Semplice effetto
Weight	Peso	22 kg
Dimensions LxWxH	Dimensioni LxPxH	485 x 175 x 273 mm

- Ideal for building and industrial works
Ideale per edilizia e industria
- Ideal for cutting metal flat bars,
Ideale per barre piatte metalliche

**TP110**

Corded flat bar cutter - Cesovia taglia piatto a filo

230V 150.00599 - 120V 150.03685



Cutting capacity	Capacità di taglio	110 x 10 mm
Cutting force	Forza di taglio	309 kN (31.5 t)
Working pressure	Pressione d'esercizio	70 MPa (700 bar)
Power supply	Alimentazione	Mains Rete elettrica
Motor	Motore	230V: 1400 W - 50 Hz - 6.8 A 120V: 1200 W - 60 Hz - 10 A
Cylinder	Effetto	Single acting Semplice effetto
Weight	Peso	40 kg
Dimensions LxWxH	Dimensioni LxPxH	572 x 175 x 342 mm

- Ideal for building and industrial works
Ideale per edilizia e industria
- Ideal for cutting metal flat bars,
Ideale per barre piatte metalliche

**TP70**

Corded flat bar cutter - Cesovia taglia piatto a filo

230V 150.00598 - 120V 150.00636



Cutting capacity	Capacità di taglio	70 x 15 mm
Cutting force	Forza di taglio	265 kN (27 t)
Working pressure	Pressione d'esercizio	60 MPa (600 bar)
Power supply	Alimentazione	Mains Rete elettrica
Motor	Motore	230V: 1400 W - 50 Hz - 6.8 A 120V: 1200 W - 60 Hz - 10 A
Cylinder	Effetto	Single acting Semplice effetto
Weight	Peso	27 kg
Dimensions LxWxH	Dimensioni LxPxH	555 x 175 x 298 mm

- Ideal for building and industrial works
Ideale per edilizia e industria
- Ideal for cutting metal flat bars,
Ideale per barre piatte metalliche

**RP5 - RP10**

Nibbler - Roditrice

RP5: 150.00751 - RP10: 150.00754



		RP5	RP10
Cutting capacity (thickness)	Capacità di taglio (spessore)	5 mm	10 mm
Cutting force	Forza di taglio	108 kN (11 t)	196.1 kN (20 t)
Working pressure	Pressione d'esercizio	70 MPa (700 bar)	70 MPa (700 bar)
Cylinder	Effetto	Double acting Doppio effetto	Double acting Doppio effetto
Weight	Peso	10 kg	18.4 kg
Dimensions LxWxH	Dimensioni LxPxH	610 x 100 x 120 mm	197 x 350 x 357 mm

- Ideal for building and industrial works
Ideale per edilizia e industria
- Designed for heavy-duty operations
Progettata per eseguire operazioni pesanti

- Ideal for cutting metal sheets,
Ideale per lastre metalliche
- Double acting
Doppio effetto

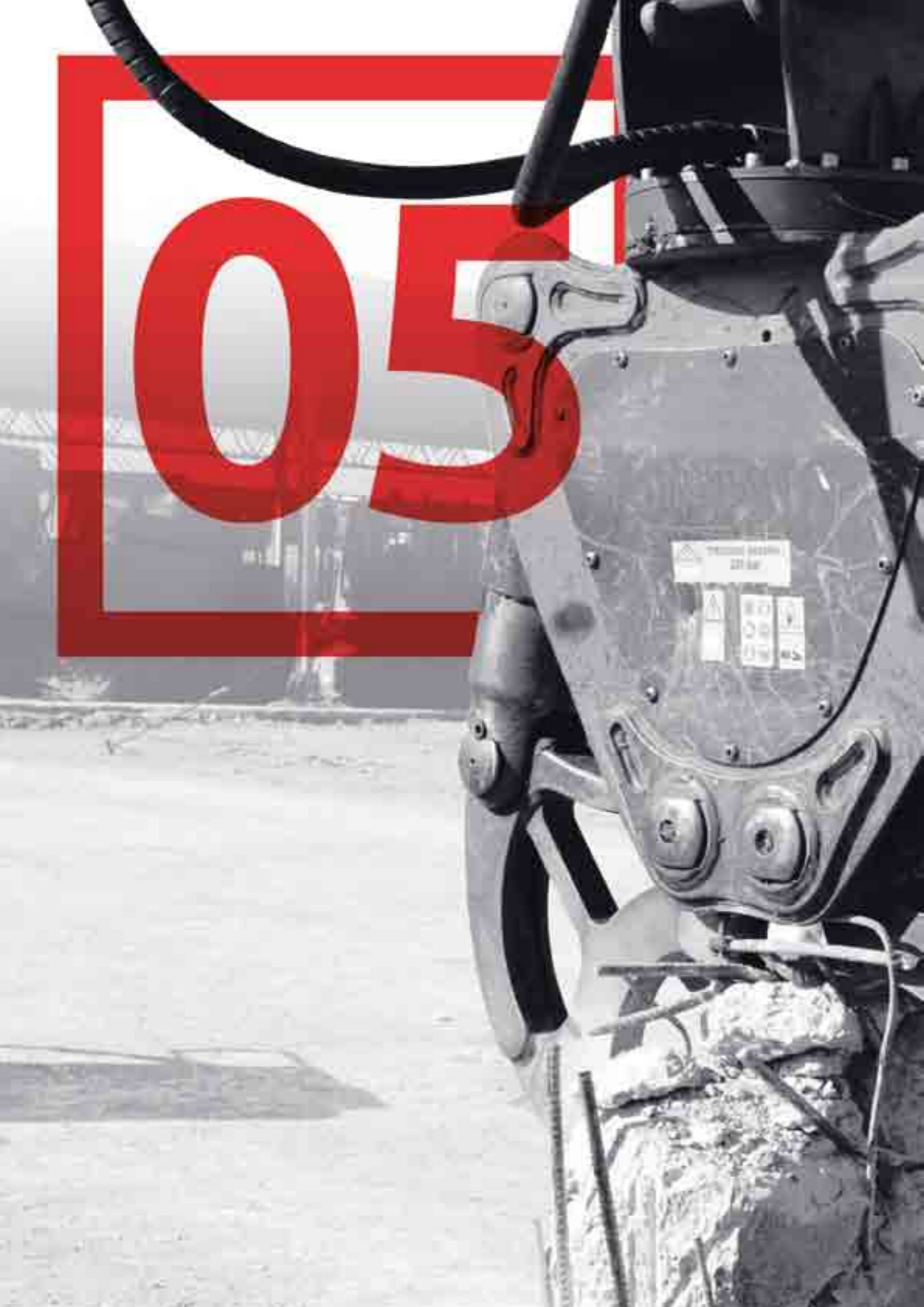

CONTROLLED DEMOLITION DEMOLIZIONE CONTROLLATA
RECYCLING RECUPERO
DECOMMISSIONING SMANTELLAMENTO

F130N T30 - 18V

Battery-powered cutter - Cesovia a batteria
150.03224



Battery and charger not included
Batteria e caricabatteria non inclusa

Blade opening	Apertura lame	130 mm
Cutting capacity	Capacità di taglio	Ø 24 mm
Cutting force	Forza di taglio	330 kN (33.7 t)
Working pressure	Pressione d'esercizio	55 MPa (550 bar)
Power supply	Alimentazione	Battery - Batteria
Motor	Motore	18V
Head rotation	Rotazione testa	180°
Cylinder	Effetto	Double acting Doppio effetto
Weight*	Peso*	12.5 kg
Dimensions (closed) LxWxH*	Dimensioni (chiuso) LxPxH*	679 x 245 x 340 mm
Dimensions (open) LxWxH*	Dimensioni (aperto) LxPxH*	665 x 245 x 340 mm

*Dimensions and weight w/o battery / Dimensioni e peso senza batteria

- Ideal for recycling and nuclear decommissioning
Ideale per recupero e smaltimento di impianti nucleari
- Lightweight and easy to handle
Leggera e facile da maneggiare
- Suitable for cutting cables, catalysts, car frames, metal sheets
Adatto al taglio di cavi, catalizzatori, telai di vetture, lamiere
- Spark-free
Senza scintille
- 180° Rotating head
Testa rotante 180°

F150N T40 S

Petrol engine cutter - Cesovia a motore a scoppio
150.02602



Blade opening	Apertura lame	150 mm
Cutting capacity	Capacità di taglio	Ø 30 mm
Cutting force	Forza di taglio	394 kN (40.2 t)
Working pressure	Pressione d'esercizio	70 MPa (700 bar)
Power supply	Alimentazione	Petrol engine / Motore a scoppio
Engine	Motore	35.8 cm³ - 4 stroke / 4 tempi
Head rotation	Rotazione testa	180°
Cylinder	Effetto	Double acting Doppio effetto
Weight	Peso	22.5 kg
Dimensions (closed) LxWxH	Dimensioni (chiuso) LxPxH	854 x 258 x 261 mm
Dimensions (open) LxWxH	Dimensioni (aperto) LxPxH	840 x 258 x 261 mm

- Ideal for recycling and nuclear decommissioning
Ideale per recupero e smaltimento di impianti nucleari
- Suitable for cutting cables, catalysts, car frames, metal sheets
Adatto al taglio di cavi, catalizzatori, telai di vetture, lamiere
- Spark-free
Senza scintille
- 180° Rotating head
Testa rotante 180°

F130N T30

Corded cutter - Cesovia a filo
230V 150.02598 - 120V 150.02600

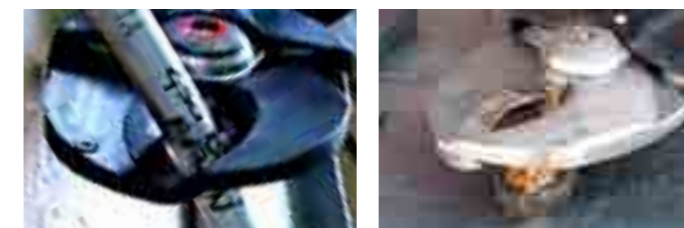

Blade opening	Apertura lame	130 mm
Cutting capacity	Capacità di taglio	Ø 22 mm
Cutting force	Forza di taglio	175 kN (17.6 t)
Working pressure	Pressione d'esercizio	55 MPa (550 bar)
Power supply	Alimentazione	Mains Rete elettrica
Motor	Motore	230V: 1100 W - 50 Hz - 5.3 A 120V: 1200 W - 60 Hz - 10 A
Head rotation	Rotazione testa	180°
Cylinder	Effetto	Double acting Doppio effetto
Weight	Peso	14.7 kg
Dimensions (closed) LxWxH	Dimensioni (chiuso) LxPxH	662 x 245 x 252 mm
Dimensions (open) LxWxH	Dimensioni (aperto) LxPxH	648 x 245 x 252 mm

- Ideal for recycling and nuclear decommissioning
Ideale per recupero e smaltimento di impianti nucleari
- Lightweight and easy to handle
Leggera e facile da maneggiare
- Suitable for cutting cables, catalysts, car frames, metal sheets
Adatto al taglio di cavi, catalizzatori, telai di vetture, lamiere
- Spark-free
Senza scintille
- 180° Rotating head
Testa rotante 180°

F150N T40

Corded cutter - Cesovia a filo
230V 150.02590 - 120V 150.02591



Blade opening	Apertura lame	150 mm
Cutting capacity	Capacità di taglio	Ø 30 mm
Cutting force	Forza di taglio	408.7 kN (41.7 t)
Working pressure	Pressione d'esercizio	70 MPa (700 bar)
Power supply	Alimentazione	Mains Rete elettrica
Motor	Motore	230V: 1100 W - 50 Hz - 5.3 A 120V: 1200 W - 60 Hz - 10 A
Head rotation	Rotazione testa	180°
Cylinder	Effetto	Double acting Doppio effetto
Weight	Peso	20.6 kg
Dimensions (closed) LxWxH	Dimensioni (chiuso) LxPxH	778 x 273 x 265 mm
Dimensions (open) LxWxH	Dimensioni (aperto) LxPxH	764 x 273 x 265 mm

- Ideal for recycling and nuclear decommissioning
Ideale per recupero e smaltimento di impianti nucleari
- Lightweight and easy to handle
Leggera e facile da maneggiare
- Suitable for cutting cables, catalysts, car frames, metal sheets
Adatto al taglio di cavi, catalizzatori, telai di vetture, lamiere
- Spark-free
Senza scintille
- 180° Rotating head
Testa rotante 180°

F130N - F145N - F170N ELECTRIC DRIVE / AZIONAMENTO ELETTRICO

Cutter - Cesoa

F130N: 150.02067 - F145N: 150.02770 - F170N: 150.02796



Hose included (3 m - 700 bar)
Tubazione inclusa (3 m - 700 bar)

		F130N	F145N	F170N
Blade opening	Apertura lame	130 mm	145 mm	170 mm
Cutting capacity	Capacità di taglio	Ø 24 mm	Ø 26 mm	Ø 28 mm
Cutting force	Forza di taglio	240 kN	363 kN	765 kN
Piston force	Forza al pistone	128 kN (13.1 t)	157 kN (16 t)	260 kN (26.5 t)
Working pressure	Pressione d'esercizio	70 MPa (700 bar)	70 MPa (700 bar)	70 MPa (700 bar)
Cylinder	Effetto	Double acting Doppio effetto	Double acting Doppio effetto	Double acting Doppio effetto
Weight	Peso	12.3 kg	17.8 kg	24.2 kg
Dimensions (closed) LxWxH	Dimensioni (chiuso) LxPxH	653 x 234 x 193 mm	749 x 250 x 180 mm	798 x 254 x 196 mm
Dimensions (open) LxWxH	Dimensioni (aperto) LxPxH	640 x 234 x 193 mm	738 x 250 x 180 mm	783 x 269 x 196 mm

F130N - F145N - F170N MECHANICAL DRIVE / AZIONAMENTO MECCANICO

Cutter - Cesoa

F130N: 150.02055 - F145N: 150.02049 - F170N: 150.02033



- Ideal for recycling and nuclear decommissioning
Ideale per recupero e smaltimento di impianti nucleari
- Lightweight and easy to handle
Leggera e facile da maneggiare
- Suitable for cutting cables, catalysts, car frames, metal sheets, aluminium and steel profiles
Adatto al taglio di cavi, catalizzatori, telai di vetture, lamiere, profili in acciaio e alluminio
- Spark-free
Senza scintille

		F130N	F145N	F170N
Blade opening	Apertura lame	130 mm	145 mm	170 mm
Cutting capacity	Capacità di taglio	Ø 24 mm	Ø 26 mm	Ø 28 mm
Cutting force	Forza di taglio	240 kN	363 kN	765 kN
Piston force	Forza al pistone	128 kN (13.1 t)	157 kN (16 t)	260 kN (26.5 t)
Working pressure	Pressione d'esercizio	70 MPa (700 bar)	70 MPa (700 bar)	70 MPa (700 bar)
Cylinder	Effetto	Double acting Doppio effetto	Double acting Doppio effetto	Double acting Doppio effetto
Weight	Peso	12.2 kg	17.5 kg	23.8 kg
Dimensions (closed) LxWxH	Dimensioni (chiuso) LxPxH	602 x 234 x 172 mm	698 x 250 x 159 mm	747 x 254 x 175 mm
Dimensions (open) LxWxH	Dimensioni (aperto) LxPxH	590 x 234 x 172 mm	688 x 250 x 159 mm	733 x 269 x 175 mm

F130N: HPU to suit - Centralina consigliata:
VDS700 G28: 150.02082

F145N: HPU to suit - Centralina consigliata:
CB700: 150.00798

F170N: HPU to suit - Centralina consigliata:
CB700: 150.00798

F180-2P BO 54V

Cutter - Cesoa

150.03643



Blade opening	Apertura lame	185 mm
Cutting capacity	Capacità di taglio	Ø 24 mm
Cutting force	Forza di taglio	298 kN (30.4 t)
Working pressure	Pressione d'esercizio	70 MPa (700 bar)
Power supply	Alimentazione	Battery - Batteria
Head rotation	Rotazione testa	180°
Cylinder	Effetto	Double acting Doppio effetto
Weight	Peso	22.46 kg
Dimensions (closed) LxWxH	Dimensioni (chiuso) LxPxH	832 x 262 x 283 mm
Dimensions (open) LxWxH	Dimensioni (aperto) LxPxH	817 x 280 x 283 mm

- Ideal for recycling and nuclear decommissioning
Ideale per recupero e smaltimento di impianti nucleari
- Lightweight and easy to handle
Leggera e facile da maneggiare
- Suitable for cutting cables, catalysts, car frames, metal sheets, aluminium and steel profiles
Adatto al taglio di cavi, catalizzatori, telai di vetture, lamiere, profili in acciaio e alluminio
- Spark-free
Senza scintille

Battery and charger not included
Batteria e caricabatteria non inclusa

MDC300 T30 - 18V

Battery-powered combi tool - Attrezzo combinato a batteria

150.03185



Blade opening	Apertura lame	300 mm
Cutting capacity	Capacità di taglio	Ø 24 mm
Cutting force	Forza di taglio	375 kN (38.2 t)
Min spreading force	Forza divaricazione min	46 kN (4.7 t)
Max spreading force	Forza divaricazione max	134 kN (13.7 t)
Pulling force	Forza trazione	45 kN (4.6 t)
Squeezing force	Forza schiacciamento	64 kN (6.5 t)
Working pressure	Pressione d'esercizio	55 MPa (550 bar)
Power supply	Alimentazione	Battery - Batteria
Motor	Motore	18V
Head rotation	Rotazione testa	180°
Cylinder	Effetto	Double acting Doppio effetto
Weight*	Peso*	12.5 kg
Dimensions (closed) LxWxH*	Dimensioni (chiuso) LxPxH*	748 x 245 x 339 mm
Dimensions (open) LxWxH*	Dimensioni (aperto) LxPxH*	676 x 304 x 339 mm

*Dimensions and weight w/o battery / Dimensioni e peso senza batteria

Accessories - Accessori

MDC300 Pulling kit (chains + hooks) | MDC300 Kit trazione (catene + ganci) | 150.02426

- Ideal for recycling and nuclear decommissioning
Ideale per recupero e smaltimento di impianti nucleari
- Lightweight and easy to handle
Leggera e facile da maneggiare
- Suitable for cutting cables, car frames, metal sheets
Adatto al taglio di cavi, telai di vetture, lamiere

Battery and charger not included
Batteria e caricabatteria non inclusa

MDC300 T30 S

Petrol engine combi tool - Attrezzo combinato a motore a scoppio

150.02597



Blade opening	Apertura lame	300 mm
Cutting capacity	Capacità di taglio	Ø 24 mm
Cutting force	Forza di taglio	330 kN (33.7 t)
Min spreading force	Forza divaricazione min	46 kN (4.7 t)
Max spreading force	Forza divaricazione max	134 kN (13.7 t)
Pulling force	Forza trazione	78 kN (8 t)
Squeezing force	Forza schiacciamento	64 kN (6.5 t)
Working pressure	Pressione d'esercizio	55 MPa (550 bar)
Power supply	Alimentazione	Petrol engine/motore a scoppio
Motor	Motore	25 cm³ - 4 stroke/4 tempi
Head rotation	Rotazione testa	180°
Cylinder	Effetto	Double acting Doppio effetto
Weight	Peso	15.4 kg
Dimensions (closed) LxWxH	Dimensioni (chiuso) LxPxH	801 x 245 x 253 mm
Dimensions (open) LxWxH	Dimensioni (aperto) LxPxH	731 x 300 x 253 mm

Accessories - Accessori

MDC300 Pulling kit (chains + hooks) | MDC300 Kit trazione (catene + ganci) | **150.02426**

- Ideal for recycling and nuclear decommissioning
Ideale per recupero e smaltimento di impianti nucleari
- Suitable for cutting cables, car frames, metal sheets
Adatto al taglio di cavi, telai di vetture, lamiere

MDC360 T40 S

Petrol engine combi tool - Attrezzo combinato a motore a scoppio

150.02603



Blade opening	Apertura lame	360 mm
Cutting capacity	Capacità di taglio	Ø 30 mm
Cutting force	Forza di taglio	394 kN (40.2 t)
Min spreading force	Forza divaricazione min	57 kN (5.8 t)
Max spreading force	Forza divaricazione max	166 kN (16.9 t)
Pulling force	Forza trazione	50 kN (5.1 t)
Squeezing force	Forza schiacciamento	72 kN (7.3 t)
Working pressure	Pressione d'esercizio	70 MPa (700 bar)
Power supply	Alimentazione	Petrol engine/motore a scoppio
Motor	Motore	35.8 cm³ - 4 stroke/4 tempi
Head rotation	Rotazione testa	180°
Cylinder	Effetto	Double acting Doppio effetto
Weight	Peso	21.7 kg
Dimensions (closed) LxWxH	Dimensioni (chiuso) LxPxH	923 x 273 x 262 mm
Dimensions (open) LxWxH	Dimensioni (aperto) LxPxH	833 x 360 x 262 mm

Accessories - Accessori

MDC360 Pulling kit (chains + hooks) | MDC360 Kit trazione (catene + ganci) | **150.02427**

- Ideal for recycling and nuclear decommissioning
Ideale per recupero e smaltimento di impianti nucleari
- Suitable for cutting cables, car frames, metal sheets
Adatto al taglio di cavi, telai di vetture, lamiere

MDC300 T30

Corded combi tool - Attrezzo combinato a filo

230V 150.02599 - 120V 150.02601



Blade opening	Apertura lame	300 mm
Cutting capacity	Capacità di taglio	Ø 22 mm
Cutting force	Forza di taglio	330 kN (33.7 t)
Min spreading force	Forza divaricazione min	46 kN (4.7 t)
Max spreading force	Forza divaricazione max	134 kN (13.7 t)
Pulling force	Forza trazione	78 kN (8 t)
Squeezing force	Forza schiacciamento	64 kN (6.5 t)
Working pressure	Pressione d'esercizio	55 MPa (550 bar)
Power supply	Alimentazione	Mains Rete elettrica
Motor	Motore	230V: 1100 W - 50 Hz - 5.3 A 120V: 1200 W - 60 Hz - 10 A
Head rotation	Rotazione testa	180°
Cylinder	Effetto	Double acting Doppio effetto
Weight	Peso	15.4 kg
Dimensions (closed) LxWxH	Dimensioni (chiuso) LxPxH	733 x 302 x 254 mm
Dimensions (open) LxWxH	Dimensioni (aperto) LxPxH	660 x 245 x 254 mm

Accessories - Accessori

MDC300 Pulling kit (chains + hooks) | MDC300 Kit trazione (catene + ganci) | **150.02426**

- Ideal for recycling and nuclear decommissioning
Ideale per recupero e smaltimento di impianti nucleari
- Lightweight and easy to handle
Leggera e facile da maneggiare
- Suitable for cutting cables, car frames, metal sheets
Adatto al taglio di cavi, telai di vetture, lamiere

MDC360 T40

Corded combi tool - Attrezzo combinato a filo

230V 150.02592 - 120V 150.02593



Blade opening	Apertura lame	360 mm
Cutting capacity	Capacità di taglio	Ø 30 mm
Cutting force	Forza di taglio	394 kN (40.2 t)
Min spreading force	Forza divaricazione min	57 kN (5.8 t)
Max spreading force	Forza divaricazione max	166 kN (16.9 t)
Pulling force	Forza trazione	50 kN (5.1 t)
Squeezing force	Forza schiacciamento	72 kN (7.3 t)
Working pressure	Pressione d'esercizio	70 MPa (700 bar)
Power supply	Alimentazione	Mains Rete elettrica
Motor	Motore	230V: 1100 W - 50 Hz - 5.3 A 120V: 1200 W - 60 Hz - 10 A
Head rotation	Rotazione testa	180°
Cylinder	Effetto	Double acting Doppio effetto
Weight	Peso	20 kg
Dimensions (closed) LxWxH	Dimensioni (chiuso) LxPxH	846 x 273 x 261 mm
Dimensions (open) LxWxH	Dimensioni (aperto) LxPxH	756 x 362 x 261 mm

Accessories - Accessori

MDC360 Pulling kit (chains + hooks) | MDC360 Kit trazione (catene + ganci) | **150.02427**

- Ideal for recycling and nuclear decommissioning
Ideale per recupero e smaltimento di impianti nucleari
- Lightweight and easy to handle
Leggera e facile da maneggiare
- Suitable for cutting cables, car frames, metal sheets
Adatto al taglio di cavi, telai di vetture, lamiere

230DE T10

Crusher - Pinza demolitrice

150.02237



Jaws opening	Apertura ganasce	230 mm
Crushing capacity	Capacità di frantumazione	200 mm
Crushing force	Forza di frantumazione	104 kN (10.6 t)
Working pressure	Pressione d'esercizio	70 MPa (700 bar)
Cylinder	Effetto	Double acting Doppio effetto
Weight	Peso	23.4 kg
Dimensions (closed) LxWxH	Dimensioni (chiuso) LxPxH	874 x 426 x 212 mm
Dimensions (open) LxWxH	Dimensioni (aperto) LxPxH	801 x 510 x 212 mm

- Ideal for controlled demolition and renovation
Ideale per demolizione controllata e ristrutturazione
- Suitable for crushing bricks and concrete walls
Adatto alla frantumazione di muri in laterizio e calcestruzzo
- Lightweight and easy to handle
Leggera e facile da maneggiare
- Equipped with safety shield
Dotata di schermo protettivo
- It reduces annoying noises, vibrations and dust
Riduce rumori, vibrazioni e polveri fastidiose

330DE T6

Hollow brick crusher - Pinza demolitrice per laterizio

150.02301



Jaws opening	Apertura ganasce	330 mm
Crushing capacity	Capacità di frantumazione	300 mm
Crushing force	Forza di frantumazione	64 kN (6.5 t)
Working pressure	Pressione d'esercizio	70 MPa (700 bar)
Cylinder	Effetto	Double acting Doppio effetto
Weight	Peso	18.1 kg
Dimensions (open) LxWxH	Dimensioni (aperto) LxPxH	706 x 480 x 210 mm

- Ideal for controlled demolition and renovation
Ideale per demolizione controllata e ristrutturazione
- Suitable for crushing bricks and concrete walls
Adatto alla frantumazione di muri in laterizio e calcestruzzo
- Lightweight and easy to handle
Leggera e facile da maneggiare
- Equipped with safety shield
Dotata di schermo protettivo
- It reduces annoying noises, vibrations and dust
Riduce rumori, vibrazioni e polveri fastidiose

315DE

Crusher - Pinza demolitrice

150.00691



Jaws opening	Apertura ganasce	315 mm standard tips - puntali standard 235 mm long tips - puntali lunghi
Crushing capacity	Capacità di frantumazione	300 mm standard tips - puntali standard 200 mm long tips - puntali lunghi
Crushing force	Forza di frantumazione	308.9 kN (31.5 t)
Working pressure	Pressione d'esercizio	70 MPa (700 bar)
Cylinder	Effetto	Double acting Doppio effetto
Weight	Peso	52 kg
Dimensions (closed) LxWxH	Dimensioni (chiuso) LxPxH	862 x 745 x 427 mm
Dimensions (open) LxWxH	Dimensioni (aperto) LxPxH	900 x 745 x 427 mm

Accessories - Accessori

Balancer	Bilanciatore	110.04304
Tip (R - short)	Puntale (DX - corto)	150.00726
Tip (L - short)	Puntale (SX - corto)	150.00765
Tip (R - long)	Puntale (DX - lungo)	150.00727
Tip (L - long)	Puntale (SX - lungo)	150.00764

430DE

Hydraulic crusher - Pinza demolitrice idraulica

150.00974



Jaws opening	Apertura ganasce	430 mm
Crushing capacity	Capacità di frantumazione	400 mm 300 mm (w/ tips) (con puntali)
Crushing force	Forza di frantumazione	549 kN (56 t)
Working pressure	Pressione d'esercizio	70 MPa (700 bar)
Cylinder	Effetto	Double acting Doppio effetto
Weight	Peso	90 kg
Dimensions (open) LxWxH	Dimensioni (aperto) LxPxH	795 x 145 x 603 mm

- Ideal for controlled demolition and renovation
Ideale per demolizione controllata e ristrutturazione
- Suitable for crushing bricks and concrete walls
Adatto alla frantumazione di muri in laterizio e calcestruzzo
- Excellent for the demolition of buildings, stairs, pillars, beams...
Ottima per la demolizione di fabbricati, scale, pilastri, travi...
- It reduces annoying noises, vibrations and dust
Riduce rumori, vibrazioni e polveri fastidiose
- Equipped with lifting hook
Dotata di gancio di sollevamento

Accessories - Accessori

Balancer	Bilanciatore	110.03251
----------	--------------	------------------

430 T34DE

Excavator mounted adjustable crusher - Pinza demolitrice regolabile per escavatore

150.02139



- Ideal for controlled demolition and renovation
Ideale per demolizione controllata e ristrutturazione
- Equipped with a jaw adjustment system
Dotata di sistema per regolazione delle ganasce
- Suitable for crushing bricks and concrete walls
Adatto alla frantumazione di muri in laterizio e calcestruzzo
- Excellent for the demolition of buildings, stairs, pillars, beams...
Ottima per la demolizione di fabbricati, scale, pilastri, travi...

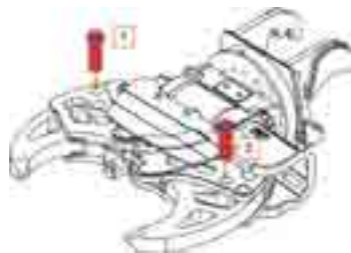

Jaws opening min - max	Apertura ganasce min - max	25² ÷ 431 mm¹
Crushing capacity	Capacità di frantumazione	400 mm
Crushing force	Forza di frantumazione	335 kN (34.2 t)¹ 317 kN (32.3 t)²
Rebar cutting capacity	Capacità di taglio tondino	Ø 28 mm
Rebar cutting force	Forza taglio tondino	920 kN (93.8 t)
Max inlet pressure	Pressione d'ingresso max	20 MPa (200 bar)
Working pressure	Pressione d'esercizio	20 MPa (200 bar)
Max flow	Portata	150 l/min
Jaws depth	Profondità ganasce	185 mm
Head rotation	Rotazione della testa	360°
Closing-opening time (Q= 42 l/min)	Tempo chiusura-apertura (Q= 42 l/min)	3 ÷ 4 s (Q= 70 l/min)
Weight*	Peso*	159 kg
Dimensions (open) LxWxH*	Dimensioni (aperto) LxPxH*	730 x 322 x 805 mm
Excavator weight min - max**	Peso escavatore min - max**	1500 ÷ 5000 kg

*Dimensions and weight w/o bracket / Dimensioni e peso senza sella
** Depending on excavator lifting capacity / Dipende dalla capacità di carico dell'escavatore

¹ Pins in external position / Pini in posizione esterna (1)
² Pins in external position / Pini in posizione interna (2)

Accessories - Accessori

Pulverizing tip	Puntale frantumazione	150.01563
-----------------	-----------------------	------------------



430-2DE T44

Excavator mounted crusher - Pinza demolitrice per escavatore

150.02120



- Ideal for controlled demolition and renovation
Ideale per demolizione controllata e ristrutturazione
- Suitable for crushing bricks and concrete walls
Adatto alla frantumazione di muri in laterizio e calcestruzzo
- Excellent for the demolition of buildings, stairs, pillars, beams...
Ottima per la demolizione di fabbricati, scale, pilastri, travi...

Jaws opening min - max	Apertura ganasce min - max	31 ÷ 435 mm
Crushing capacity	Capacità di frantumazione	400 mm
Crushing force	Forza di frantumazione	440 kN (44.9 t)
Rebar cutting capacity	Capacità di taglio tondino	Ø 30 mm
Rebar cutting force	Forza taglio tondino	1400 kN (143 t)
Max inlet pressure	Pressione d'ingresso max	20 MPa (200 bar)
Working pressure	Pressione d'esercizio	50 MPa (500 bar)
Max flow	Portata	100 l/min
Jaws depth	Profondità ganasce	195 mm
Head rotation	Rotazione della testa	360°
Jaws closing-opening time	Tempo chiusura-apertura lame	3 ÷ 2.5 s (Q= 70 l/min)
Weight*	Peso*	245 kg
Dimensions (open) LxWxH*	Dimensioni (aperto) LxPxH*	883 x 323 x 918 mm
Excavator weight min - max**	Peso escavatore min - max**	3000 ÷ 5000 kg

*Dimensions and weight w/o bracket / Dimensioni e peso senza sella
** Depending on excavator lifting capacity / Dipende dalla capacità di carico dell'escavatore

Accessories - Accessori

Pulverizing tip	Puntale frantumazione	150.01579
-----------------	-----------------------	------------------

- Equipped with blades for cutting rods and rods
Dotata di coltelli per il taglio di tondini e barre tonde
- 360° head rotation
Testa rotante 360°



F200C - F250C

Excavator mounted cutter - Cesoia per escavatore

F200C: 150.02380 - F250C: 150.02446



- Ideal for controlled demolition and renovation
Ideale per demolizione controllata e ristrutturazione
- Suitable for cutting cables, pipes, I-beams, metal beams...
Adatto al taglio di cavi, tubi, putrelle, travi metalliche...
- Excellent for the decommissioning of buildings, stairs, pillars, beams...
Ottima per la demolizione di fabbricati, scale, pilastri, travi...
- 360° head rotation
Testa rotante 360°

		F200C	F250C
Blade opening	Apertura lame	205 mm	250 mm
Max cutting force	Forza taglio max	841 kN (85.8 t)	841 kN (85.8 t)
Max inlet pressure	Pressione d'ingresso max	20 MPa (200 bar)	20 MPa (200 bar)
Working pressure	Pressione d'esercizio	25 MPa (250 bar)	20 MPa (200 bar)
Max flow	Portata	150 l/min	150 l/min
Blades depth	Profondità lame	158 mm	225 mm
Head rotation	Rotazione della testa	360°	360°
Blades closing-opening time	Tempo chiusura-apertura lame	2 ÷ 1.5 s (Q= 65 l/min)	2 ÷ 1.5 s (Q= 65 l/min)
Weight*	Peso*	178 kg	182 kg
Dimensions (open) LxWxH*	Dimensioni (aperto) LxPxH*	1043 x 220 x 325 mm	1083 x 220 x 325 mm
Excavator weight min - max**	Peso escavatore min - max**	1500 ÷ 5000 kg	1500 ÷ 5000 kg

*Dimensions and weight w/o bracket / Dimensioni e peso senza sella
** Depending on excavator lifting capacity / Dipende dalla capacità di carico dell'escavatore

F300C

Excavator mounted cutter - Cesoia per escavatore

150.02552



Blade opening	Apertura lame	300 mm
Max cutting force	Forza taglio max	1060 kN (108.1 t)
Max inlet pressure	Pressione d'ingresso max	20 MPa (200 bar)
Working pressure	Pressione d'esercizio	25 MPa (250 bar)
Max flow	Portata	150 l/min
Blades depth	Profondità lame	250 mm
Head rotation	Rotazione della testa	360°
Blades closing-opening time	Tempo chiusura-apertura lame	2 ÷ 1.5 s (Q= 65 l/min)
Weight*	Peso*	310 kg
Dimensions (open) LxWxH*	Dimensioni (aperto) LxPxH*	1352 x 320 x 486 mm
Excavator weight min - max**	Peso escavatore min - max**	1500 ÷ 5000 kg

*Dimensions and weight w/o bracket / Dimensioni e peso senza sella
** Depending on excavator lifting capacity / Dipende dalla capacità di carico dell'escavatore

- Ideal for controlled demolition and renovation
Ideale per demolizione controllata e ristrutturazione
- Suitable for cutting cables, pipes, I-beams, metal beams...
Adatto al taglio di cavi, tubi, putrelle, travi metalliche...
- Excellent for the decommissioning of buildings, stairs, pillars, beams...
Ottima per la demolizione di fabbricati, scale, pilastri, travi...
- It reduces annoying noises, vibrations and dust
Riduce rumori, vibrazioni e polveri fastidiose
- 360° head rotation
Testa rotante 360°



06



HYDRAULIC POWER UNITS CENTRALINE IDRAULICHE

CB700 L4

Electric motor power unit - Centralina elettrica
400V 150.00798 - **230V** 150.00846 - **110V** 150.01171

With cooler
 Con scambiatore di calore

**CB700 L4** 2 ELETTROVALVOLE / 2 SOLENOID VALVE

Electric motor power unit - Centralina elettrica
400V 150.00804



VERSION WITH COOLER
 VERSIONE CON SCAMBIATORE DI CALORE
400V 150.00835

CB700 L7

Electric motor power unit - Centralina elettrica
400V 150.02692



VERSION WITH COOLER AND 2 SOLENOID VALVE
 VERSIONE CON SCAMBIATORE DI CALORE E 2 ELETTROVALVOLE
400V 150.00855

CB700 L4S PETROL ENGINE / MOTORE A SCOPPIO

Petrol engine power unit - Centralina a motore a scoppio
 150.00794



		CB700 L4 Three-phase / Trifase 150.00798	CB700 L4 2 solenoid valves / 2 elettrovalvole 150.00804	CB700 L7 Three-phase / Trifase 150.02692	CB700 L4S Petrol engine / Motore a scoppio 150.00794
Pressure	Pressione	70 MPa (700 bar)	70 MPa (700 bar)	70 MPa (700 bar)	70 MPa (700 bar)
Oil flow	Portata olio	4 l/min	4 l/min	7.5 l/min	6 l/min (0÷100 bar) 1.6 l/min (100÷700 bar)
Oil tank capacity	Capacità serbatoio olio	23 l	23 l	90 l	23 l
RPM	RPM	1420 /min	1420 /min	1450 /min	3000 /min
Voltage	Tensione	400 V - 50 Hz - three phase	400 V - 50 Hz - three phase	400 V - 50 Hz - three phase	Petrol engine
Motor	Motore	5.5 HP - 4 kW	5.5 HP - 4 kW	5.5 HP - 4 kW	5.5 HP - 4 kW
Weight	Peso	93.2 kg	100 kg	232 kg	75 kg
Dimensions	Dimensioni	700 x 570 x 714 mm	700 x 570 x 714 mm	700 x 470 x 980 mm	700 x 570 x 668 mm

More power units available upon request
 Altre centraline disponibili su richiesta

VDS700 G28 WITH COOLER / CON SCAMBIATORE

Electric motor power unit - Centralina elettrica
230V 150.02082 - **120V** 150.02341

**VDS700 380 bar**

Electric motor power unit - Centralina elettrica
230V 150.00173

With solenoid valves
 Con elettrovalvole

**VDS700 L3 700 bar**

Electric motor power unit - Centralina elettrica
230V 150.00189 - **120V** 150.02986

With 2 solenoid valves
 Con 2 elettrovalvole

**VDS700** PETROL ENGINE / MOTORE A SCOPPIO

Petrol engine power unit - Centralina a motore a scoppio
 150.00188



		VDS700 G28 Heat exchanger / Scambiatore 150.02082	VDS700 380 bar 150.00173	VDS700 L3 700 bar 150.00189	VDS700 Petrol engine / Motore a scoppio 150.00188
Pressure	Pressione	70 MPa (700 bar)	38 MPa (380 bar)	70 MPa (700 bar)	70 MPa (700 bar)
Oil flow	Portata olio	1.2 l/min	4.2 l/min (0÷100 bar) 2.1 l/min (100÷380 bar)	3 l/min	2 l/min (0÷100 bar) 1 l/min (100÷700 bar)
Oil tank capacity	Capacità serbatoio olio	2.3 l	2.3 l	2.3 l	2.3 l
RPM	RPM	2800 /min	14 000 /min	14 000 /min	7000 /min
Voltage	Tensione	230 V - 50 Hz	230 V - 50 Hz	230 V - 50 Hz	/
Motor	Motore	1500 W	1400 W	1400 W	Petrol engine
Weight	Peso	27 kg	17.4 kg	16.9 kg	16.7 kg
Dimensions	Dimensioni	362 x 229 x 441 mm	357 x 229 x 351 mm	374 x 230 x 351 mm	342 x 282 x 464 mm

More power units available upon request
 Altre centraline disponibili su richiesta

